



TM

MONOKAST WALL SYSTEMS

*Insulated Precast Walls...
Installed by Foundation Professionals*

Builders Manual

This 2012 International Residential Code® is a copyrighted work owned by the International Code Council, Inc.

This MonoKast Builders Manual contains excerpts from
Chapter 4 Foundations
2012 International Residential Code, Copyright 2011
Washington, DC: International Code Council
reproduced with permission; all rights reserved
www.ICCSAFE.org

Table of Contents

Preparing Your Foundation for MonoKast.....	4
Identifying Your Soil.....	4
Establishing Benchmarks and Corners	4
Job Site Accessibility.....	4
Establishing a Drainage System.....	5
Crushed Stone Footings	7
Excavation Topics.....	9
When Walls Intersect.....	9
About the Overdig.....	9
About Trenching.....	10
Using MonoKast Panels as Frost Walls.....	11
Using MonoKast Panels – At Grade - Frost Considerations.....	112
Using Crushed Stone Trench Footing for Basement/Above Grade Walls in Frost Areas	1213
Using Crushed Stone Trench Footing for Basement/Above Grade Walls in Non-Frost/Shallow Frost Areas	14
How to Pour the Concrete Floor.....	15
Floor Pour.....	15
Pouring a Raised Floor	16
Crawl Spaces	18
With Wood Bracing.....	19
Without Wood Bracing.....	20
Additional Inside Fill Conditions.....	21
Garage Frost Walls	22
Framing Connections	23
Framing Connections	23
Sill Plate.....	23
Joists Perpendicular to MonoKast Panels	25
Joists Parallel to MonoKast Panels	27
“1” Joist Blocking Detail	30
Top Chord Bearing Open Floor Truss	31
Open Floor Truss Perpendicular to MonoKast Panel	31
Open Floor Truss Parallel to MonoKast Panel	32
Bottom Chord Bearing Floor Truss.....	33
Parallel to MonoKast Panel	33
Perpendicular to MonoKast Panel	33
Sill Plate/Blocking for Modular Connection	34
Connecting the Roof Truss	35
Stairwell Header Reinforcement.....	36
Parallel Joists.....	36
Perpendicular Joists.....	37
About Backfilling.....	38
Determining the Need for a Shear Wall	39

Concentrated Loads.....	40
Beam Pockets.....	40
Support Ledges.....	41
MonoKast Checklist for Builder/General Contractor.....	42
MonoKast Checklist for Excavator.....	44
MonoKast Checklist for Concrete Floor Work.....	46
MonoKast Checklist for Framing.....	47
MonoKast Checklist for Code Inspector.....	49

This MonoKast Builders Manual contains excerpts from
2012 International Residential Code, Copyright 2011
Washington, DC: International Code Council
reproduced with permission; all rights reserved
www.ICCSAFE.org

The 2012 International Residential Code® is a copyrighted work owned by the International Code Council, Inc.

Code Reference: 2012 IRC Section: Introduction
--

Internationally, code officials recognize the need for a modern, up-to-date residential code addressing the design and construction of one- and two-family dwellings and townhouses. The International Residential Code®, in this 2012 edition, is designed to meet these needs through model code regulations that safeguard the public health and safety in all communities, large and small.

This comprehensive, stand-alone residential code establishes minimum regulations for one- and two-family dwellings and townhouses using prescriptive provisions. It is founded on broad-based principles that make possible the use of new materials and new building designs. This 2012 edition is fully compatible with all of the International Codes® (I-Codes®) published by the International Code Council® (ICC)®, including the International Building Code®, International Energy Conservation Code®, International Existing Building Code®, International Fire Code®, International Fuel Gas Code®, International Green Construction Code™ (to be available March 2012), International Mechanical Code®, ICC Performance Code®, International Plumbing Code®, International Private Sewage Disposal Code®, International Property Maintenance Code®, International Swimming Pool and Spa Code™ (to be available March 2012), International Wildland-Urban Interface Code® and International Zoning Code®.

Preparing Your Foundation for MonoKast

Identifying Your Soil

1. MonoKast panels can be used on any soil that has a bearing capacity of 1,500 PSF or more.
2. Use Table 1 (page 6) to:
 - Identify your soil.
 - Identify your allowable load-bearing pressure.
 - Identify your drainage characteristics.
 - Identify the combined footing load per linear foot. Be sure to consider such factors as dead load, live load, snow and wind load. Your building designer or engineer can assist you with loading information.
3. Use Table 2 (page 7) to identify the required depth of the 1/2" clean crushed stone footing. Remember to allow for this depth when determining excavation depth.
4. For further assistance with identifying your soil, consult with:
 - Building Department
 - County Agricultural Extension Service
 - County Conservation District Officer
 - Excavator
 - Soils Technician
 - <http://websoilsurvey.nrcs.usda.gov>

Establishing Benchmarks and Corners

1. Identify the top-of-wall elevation that your building will require.
2. Set markers that will define the corners of the building to represent the exterior face of the MonoKast foundation.

Job Site Accessibility

1. The builder/homeowner is responsible to provide accessibility to the job site. Consult with your MonoKast representative concerning accessibility to the job site.
2. Driveways must be a minimum of 20' wide to allow access for a trailer and crane.
3. Driveway surfaces (and any culverts, bridges etc.) must be able to bear the weight of the trailer and crane.
4. Clear the job site access of overhead obstructions such as trees, wires etc.
5. 9'-0" and 10'-0" walls will be delivered on a drop deck trailer and will have limited ground clearance.
6. The job site should allow the crane to sit in a level crane pad area with a solid base. The crane pad area must allow each precast panel to be safely set.
7. The job site should have a level area for the trailer to be parked near the crane.

Establishing a Drainage System

Code Reference: 2012 IRC Section: R401.3

R401.3 Drainage. Surface drainage shall be diverted to a storm sewer conveyance or other approved point of collection that does not create a hazard. Lots shall be graded to drain surface water away from foundation walls. The grade shall fall a minimum of 6 inches (152 mm) within the first 10 feet (3048 mm).

Exception: Where lot lines, walls, slopes or other physical barriers prohibit 6 inches (152 mm) of fall within 10 feet (3048 mm), drains or swales shall be constructed to ensure drainage away from the structure. Impervious surfaces within 10 feet (3048 mm) of the building foundation shall be sloped a minimum of 2 percent away from the building.

Code Reference: 2012 IRC Section: R404.1.6

R404.1.6 Height above finished grade.

Concrete and masonry foundation walls shall extend above the finished grade adjacent to the foundation at all points a minimum of 4 inches (102 mm) where masonry veneer is used and a minimum of 6 inches elsewhere.

Code Reference: 2012 IRC Section: R405

R405 FOUNDATION DRAINAGE

R405.1 Concrete or masonry foundations.

Drains shall be provided around all concrete or masonry foundations that retain earth and enclose habitable or usable spaces located below grade. Drainage tiles, gravel or crushed stone drains, perforated pipe or other approved systems or materials shall be installed at or below the area to be protected and shall discharge by gravity or mechanical means into an approved drainage system. Gravel or crushed stone drains shall extend at least 1 foot (305 mm) beyond the outside edge of the footing and 6 inches (152 mm) above the top of the footing and be covered with an approved filter membrane material. The top of open joints of drain tiles shall be protected with strips of building paper. Perforated drains shall be surrounded with an approved filter membrane or the filter membrane shall cover the washed gravel or crushed rock covering the drain. Drainage tiles or perforated pipe shall be placed on a minimum of 2 inches (51 mm) of washed gravel or crushed rock at least one sieve size larger than the tile joint opening or perforation and covered with not less than 6 inches (152 mm) of the same material.

Exception: A drainage system is not required when the foundation is installed on well-drained ground or sand-gravel mixture soils according to the Unified Soil Classification System, Group I Soils, as detailed in Table R405.1.

R405.1.1 Precast concrete foundation.

Precast concrete walls that retain earth and enclose habitable or usable space located below-grade that rest on crushed stone footings shall have a perforated drainage pipe installed below the base of the wall on either the interior or exterior side of the wall, at least one foot (305 mm) beyond the edge of the wall. If the exterior drainage pipe is used, an approved filter membrane material shall cover the pipe. The drainage system shall discharge into an approved sewer system or to daylight.

1. Install a perforated drainage pipe per 2012 IRC Section R405
 - Put the perforated drainage pipe on the interior or exterior side of the panel or wall.
 - The perforated drainage pipe should be installed at least one foot (12") beyond the nearest edge of the panel or wall, regardless of whether it is located on the interior or exterior of the panel or wall.
 - Install the perforated drainage pipe in the crushed stone below the base of the panel or wall.
2. Install a sump pit or daylight drain.
 - Direct the perforated drainage pipe to the sump pit or daylight drain.
 - If a daylight drain is used, a backwater valve must be installed to prevent backflow of moist air into the stone footing area. This will reduce the likelihood of excessive interior humidity.

Note: For large foundations or in areas with a high water table, a second sump pit or daylight drain should be considered. Consult with your MonoKast representative.
3. Install a filter membrane
 - The filter membrane must be "approved" – as defined in the 2012 IRC it must be "acceptable to the building official."
 - Once approved, install the filter membrane over the crushed stone footing area on the

exterior of the panel or wall. The filter membrane should be installed prior to backfilling to prevent backfill material from clogging the stone and not draining properly.

Note: Install the filter membrane on the **exterior** of the panel or wall even if pipe is on the interior side of the panel or wall.

Table 1 Properties of Soils Classified According to the Unified Soil Classification System						
Table reference: 2012 IRC Table R405.1						
Soil Group	Unified Soil Classification System	Soil Description	Drainage characteristics (a)	Frost Heave Potential	Volume Change Potential Expansion (b)	Presumptive Load-Bearing Pressure (PSF) (d)
Group I Excellent	GW	Well graded gravel, gravel-sand mixtures, little or no fines	Good	Low	Low	3000
	GP	Poorly graded gravels or gravel sand mixtures, little or no fines	Good	Low	Low	3000
	SW	Well-graded sands, gravelly sands, little or no fines	Good	Low	Low	2000
	SP	Poorly graded sands or gravelly sands, little or no fines	Good	Low	Low	2000
	GM	Silty gravels, gravel-sand-silt mixtures	Good	Medium	Low	2000
	SM	Silty sand, sand-silt mixtures	Good	Medium	Low	2000
Group II Fair to Good	GC	Clayey gravels, gravel-sand-clay mixtures	Medium	Medium	Low	2000
	SC	Clayey sands, sand-clay mixture	Medium	Medium	Low	2000
	ML	Inorganic silts and very fine sands, rock flour, silty or clayey fine sands or clayey silts with slight plasticity	Medium	High	Low	1500 (c)
	CL	Inorganic clays of low to medium plasticity, gravelly clays, sandy clays, silty clays, lean clays	Medium	Medium	Medium to Low	1500 (c)
Group III Poor	CH	Inorganic clays of high plasticity, fat clays	Poor	Medium	High	1500 (c)
	MH	Inorganic silts, micaceous or diatomaceous fine sandy or silt soils.	Poor	High	High	1500 (c)
Group IV Unsatisfactory	OL	Organic silts and organic silty clays of low plasticity	Poor	Medium	Medium	By Test
	OH	Organic clays of medium to high plasticity, organic silts	Unsatisfactory	Medium	High	By Test
	PT	Peat and other highly organic soils	Unsatisfactory	Medium	High	By Test

(a) The percolation rate for good drainage is over 4 inches per hour, medium drainage is 2 inches to 4 inches per hour, and poor is less than 2 inches per hour.

(b) Soils with a low potential expansion typically have a plasticity index (PI) of 0 to 15, soils with a medium potential expansion have a PI of 10 to 35 and soils with a high potential expansion have a PI greater than 20.

(c) Where the building official determines that in-place soils with an allowable bearing capacity of less than 1,500 psf are likely to be present at the site, the allowable bearing capacity shall be determined by a soils investigation. 2012 IRC Table R401.4.1.

(d) Presumptive Load-Bearing Values of Foundation Materials data from 2012 IRC Table R401.4.1.

(e) CH, MH, OL, OH, and PT are unsuitable as backfill material.

Crushed Stone Footings

Code Reference: 2012 IRC Section: R403.1

R403.1 General. All exterior walls shall be supported on continuous solid or fully grouted masonry or concrete footings, crushed stone footings, wood foundations, or other approved structural systems which shall be of sufficient design to accommodate all loads according to Section R301 and to transmit the resulting loads to the soil within the limitations as determined from the character of the soil. Footings shall be supported on undisturbed natural soils or engineered fill.

Code Reference: 2012 IRC Section: R403.4.1

R403.4.1 Crushed stone footings. Clean crushed stone shall be free from organic, clayey or silty soils. Crushed stone shall be angular in nature and meet ASTM C 33, with the maximum size stone not to exceed 1/2 inch (12.7 mm) and the minimum stone size not to be smaller than 1/16-inch (1.6 mm). Crushed stone footings for precast foundations shall be installed in accordance with Figure R403.4 (1) and Table R403.4. Crushed stone footings shall be consolidated using a vibratory plate in a maximum of 8-inch lifts. Crushed stone footings shall be limited to Seismic Design Categories A, B and C.

Table 2 MINIMUM DEPTH OF CRUSHED STONE FOOTINGS (D), (inches)									
Table reference: 2012 IRC Table R403.4									
LOAD-BEARING VALUE OF SOIL (psf)									
		1500		2000		3000		4000	
		MH, CH, CL, ML		SC, GC, SM, GM, SP, SW		GP, GW			
		Wall width (inches)		Wall width (inches)		Wall width (inches)		Wall width (inches)	
		10	12	10	12	10	12	10	12
Conventional light-frame construction									
1-story	1100 plf	4	4	4	4	4	4	4	4
2-story	1800 plf	4	4	4	4	4	4	4	4
3-story	2900 plf	12	10	6	6	4	4	4	4
4-inch brick veneer over light-frame or 8-inch hollow concrete masonry									
1-story	1500 plf	4	4	4	4	4	4	4	4
2-story	2700 plf	4	4	4	4	4	4	4	4
3-story	4000 plf	20	18	12	10	6	4	4	4
8-inch solid or fully grouted masonry									
1-story	2000 plf	4	4	4	4	4	4	4	4
2-story	3600 plf	4	4	4	4	4	4	4	4
3-story	5300 plf	20	18	12	10	6	4	4	4

For SI: 1 inch = 25.4 mm; 1 pound per SI = 6.89 pounds per linear foot; 1 plf = 2.44 N/m; 1 pounds per square foot = 47.9 N/m²

1. Effective bearing width is shown in Table 3
2. Footing must be on virgin/undisturbed soil (see Figure 1)
3. Do not place footing on frozen soil
4. Protect rock from freezing
5. Evenly grade the stone to within ± 1 inch of level.
6. Be sure to have enough material on hand for use in final grading by the MonoKast installation crew.

Table 3 Crushed Stone Footing Depth/ Effective Bearing Width	
Crushed Stone Footing Depth (inches)	Effective Bearing Width (inches)
4	14-7/8
5	16
6	17-3/16
7	18-5/16
8	19-1/2
9	20-5/8
10	21-13/16
11	22-15/16
12	24-1/8
13	25-1/4
14	26-7/16
15	27-9/16
16	28-3/4
17	29-7/8
18	31-1/16
19	32-3/16
20	33-3/8
21	34-1/2
22	35-5/8

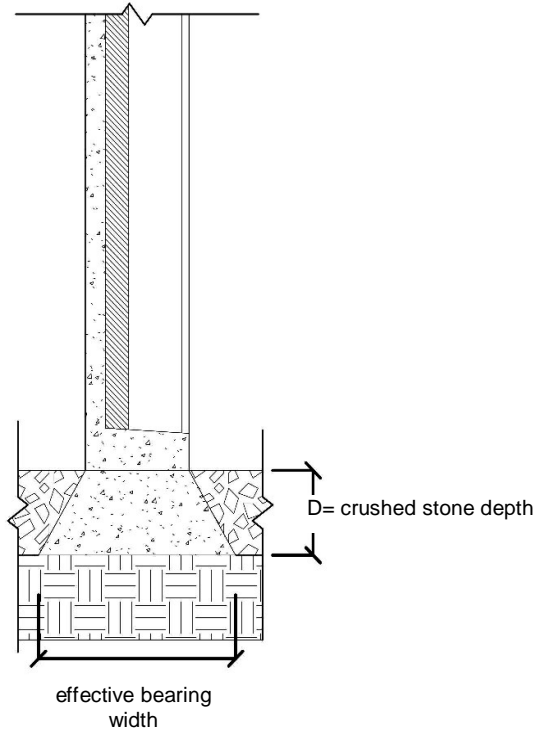
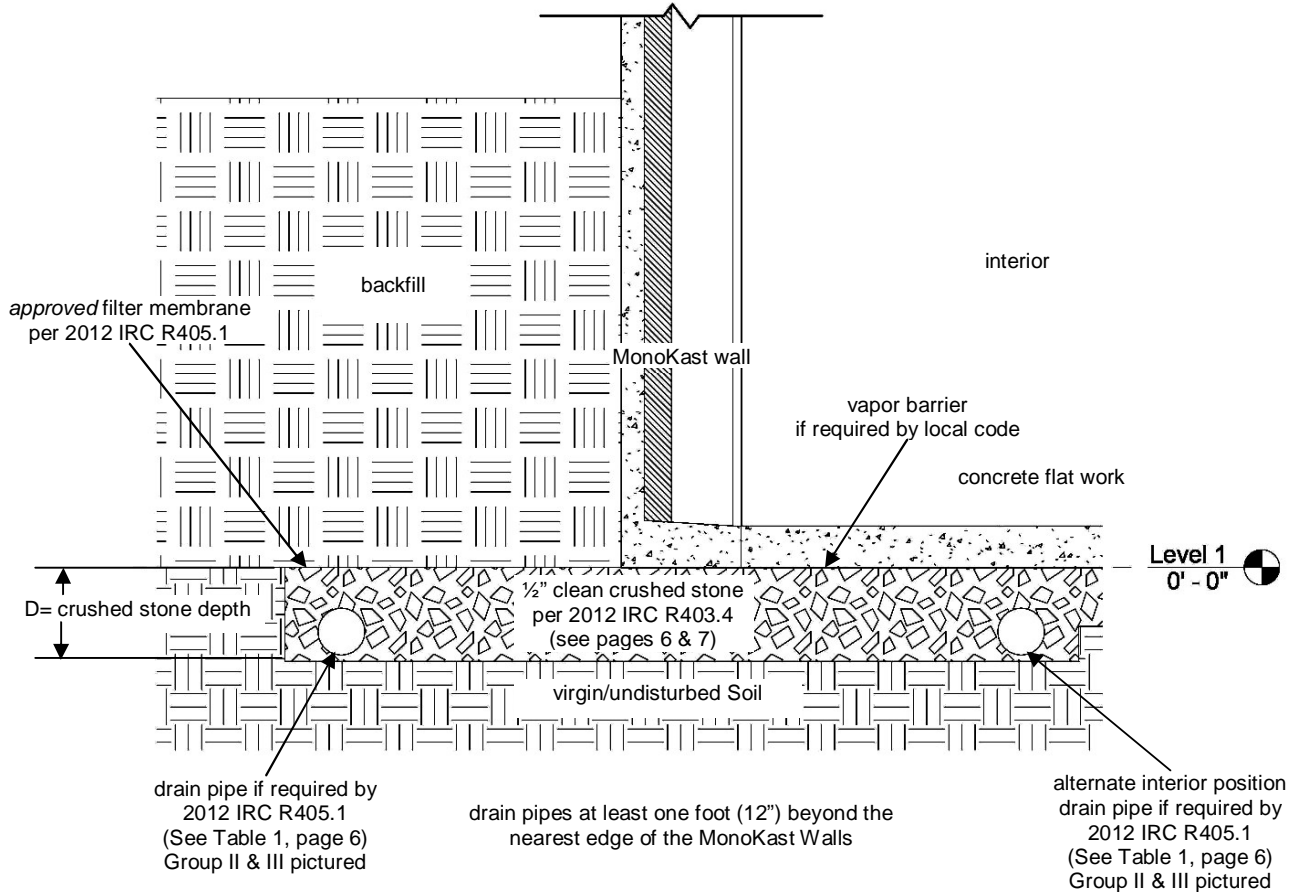

Figure 1



Excavation Topics

When Walls Intersect

1. When a wall intersects the basement wall and rests on a precast ledge, the overdig must not exceed 5'-0". (See Figure 2.)
2. When an overdig is more than 5'-0", an intermediate support column is required unless project-specific engineering is provided.

About the Overdig

1. Figure 2 illustrates the overdig procedure.
2. Figure 3 illustrates the excessive overdig procedure.

drain pipes at least one foot (12") beyond the nearest edge of the MonoKast Walls

Figure 2

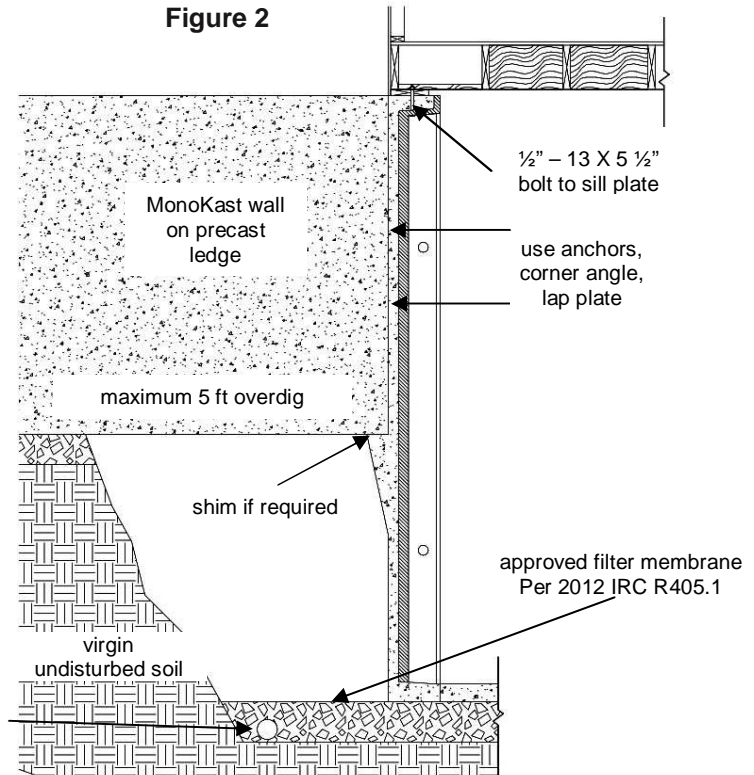
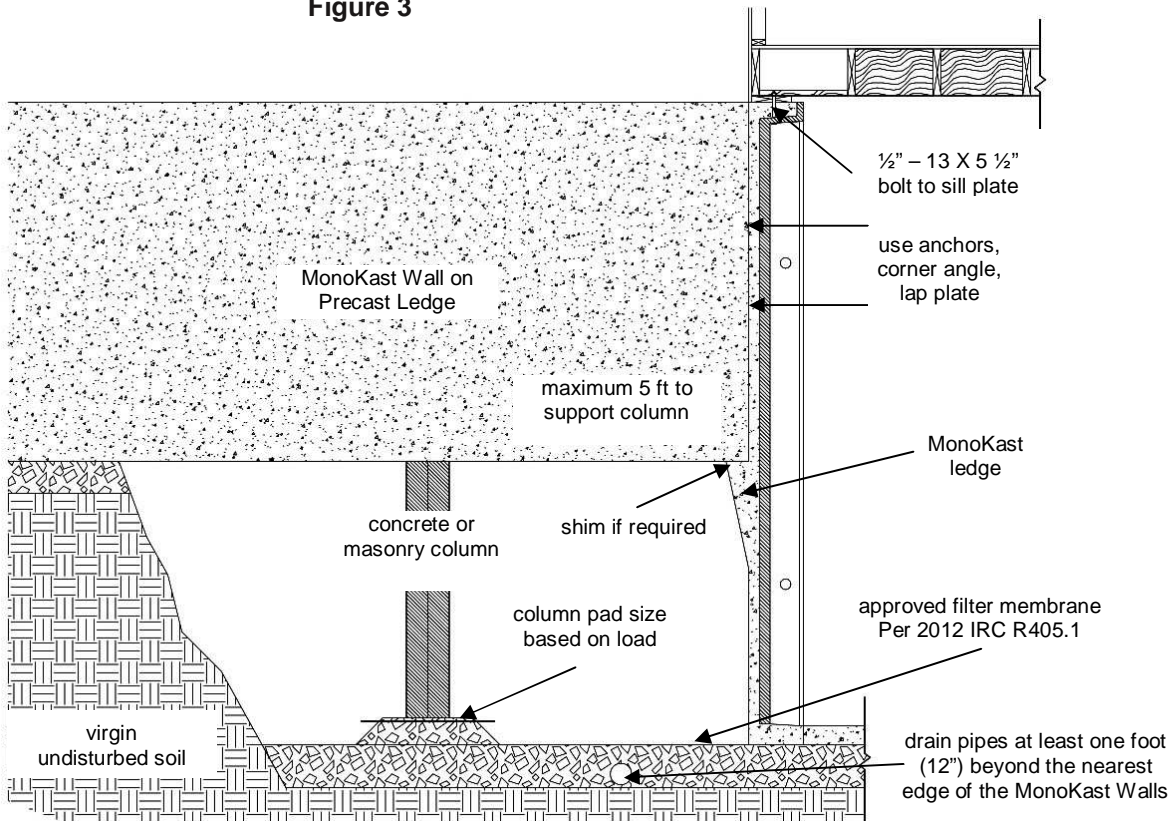

Figure 3



About Trenching

1. Trenches used in MonoKast installation must provide a minimum of 24" on both sides of the wall at the base of the excavation.
2. Dig trenches below a frost line.
3. A perforated drainage pipe is not required to be installed when walls are placed in trenches, as shown in Figure 4.

Code Reference: 2012 IRC Section: R318.4

R318.4 Foam plastic protection. In areas where the probability of termite infestation is "very heavy" as indicated in Figure R301.2(6), extruded and expanded polystyrene, polyisocyanurate and other foam plastics shall not be installed on the exterior face or under interior or exterior foundation walls or slab foundations located below grade. The clearance between foam plastics installed above grade and exposed earth shall be at least 6 inches (152 mm).

Exceptions:

1. Buildings where the structural members of walls, floors, ceilings and roofs are entirely of noncombustible materials or pressure-preservative-treated wood.
2. When in addition to the requirements of R318.1, an approved method of protecting the foam plastic and structure from subterranean termite damage is provided.
3. On the interior side of basement walls.

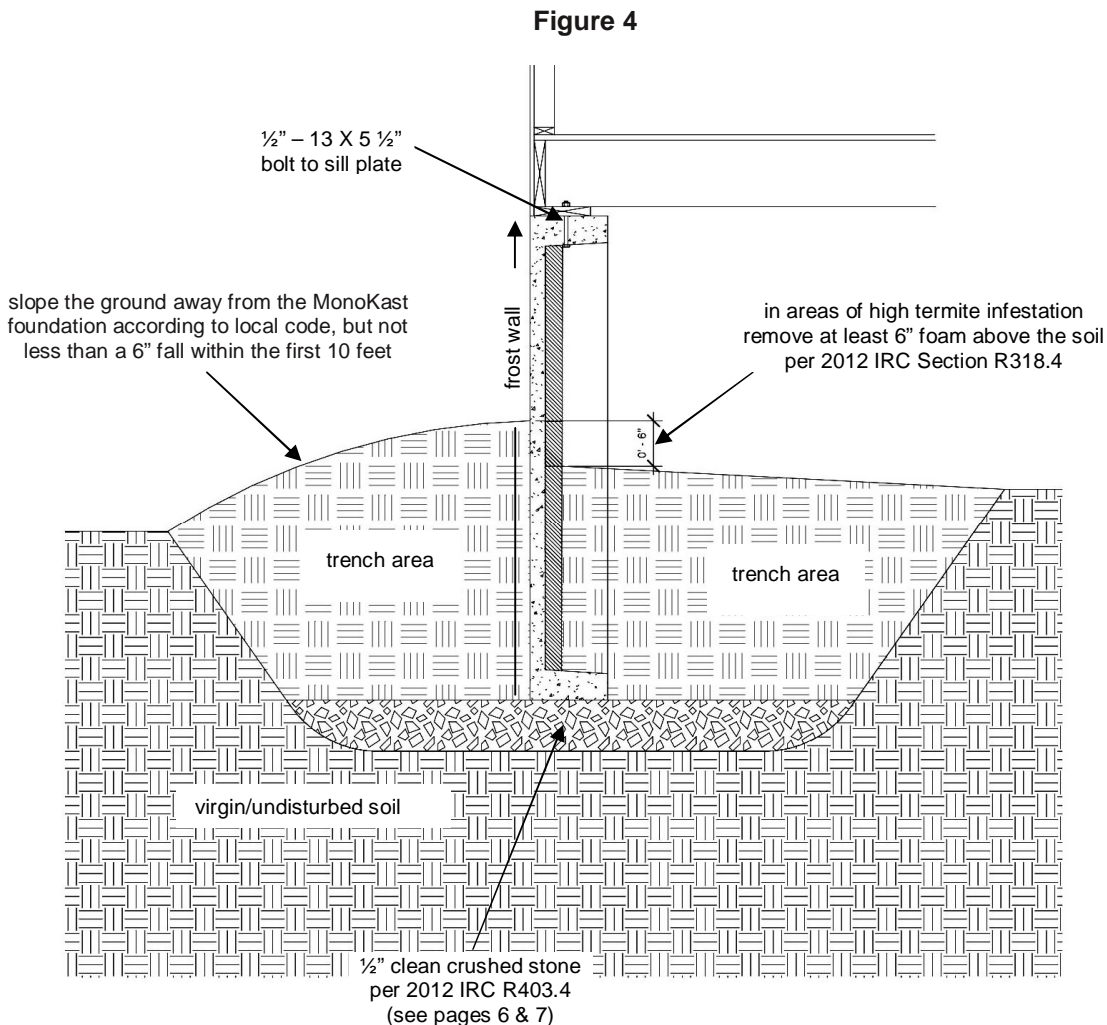

Using MonoKast Panels as Frost Walls

1. Figure 5a illustrates how to use MonoKast panels as frost walls.
2. In addition:
 - Be careful when placing backfill to avoid displacing frost walls.
 - If slab connectors are provided, bend them into the concrete floor pour.
 - Use $\frac{1}{2}$ " – 13 x 8" bolts to bolt the upper and lower walls together at a maximum of 48" on center.

Figure 5a

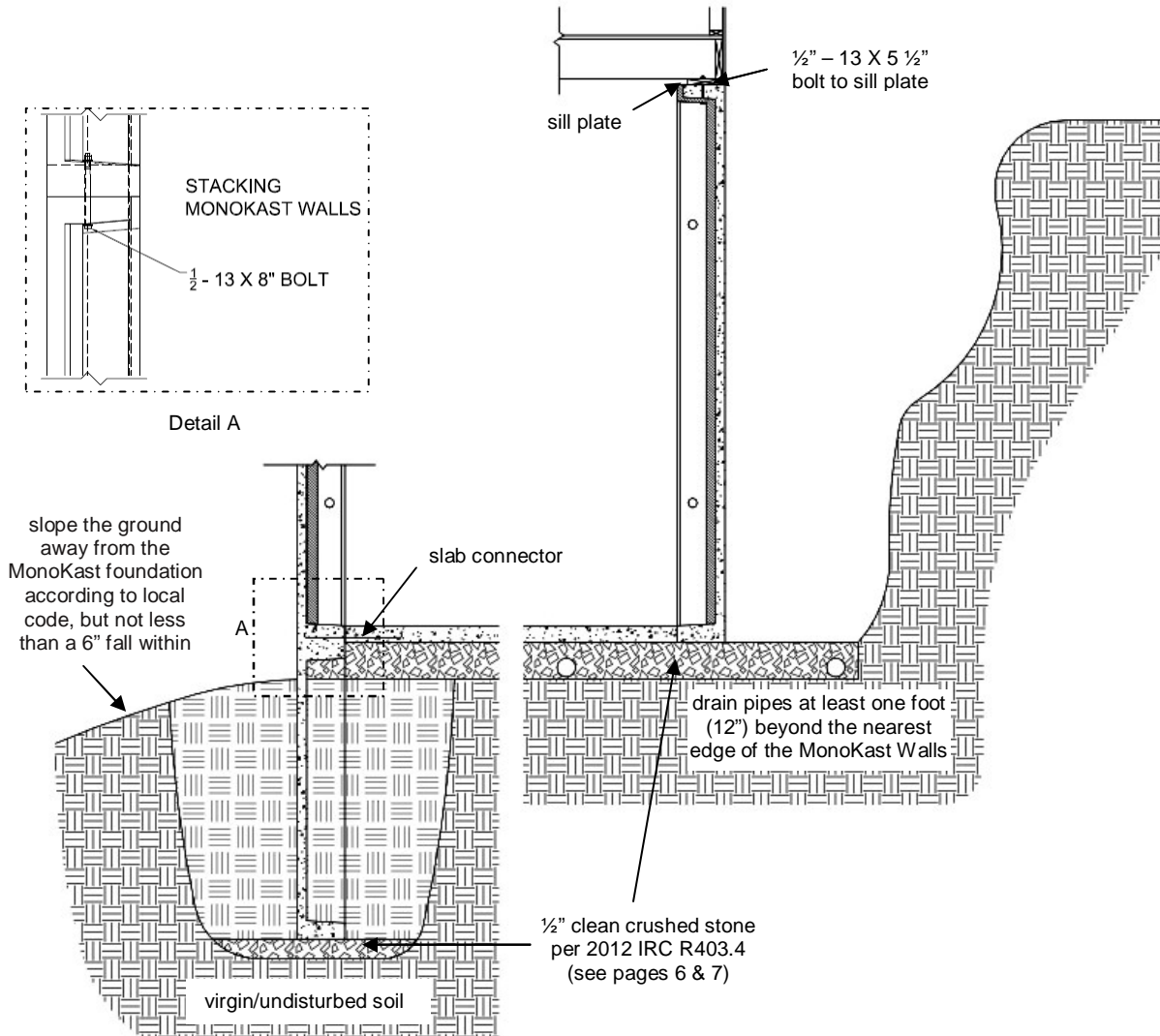

Using MonoKast Panels – At Grade – Frost Area Considerations

1. Fig 5b illustrates use of MonoKast panels in areas with frost consideration.
2. This configuration utilizes the Crushed Stone Trench Footings, ref. pgs 7-8.
3. General Requirements:
 - The bottom and both sides of the trench must be in virgin, undisturbed soil.
 - The trench shall be 36" wide.
 - The bottom of the trench shall extend below the local frost depth.
 - Using a drainage pipe per 2012 IRC Section R405, provide an outlet to daylight or to a sump pit with a pump.
 - Do NOT place a continuous pipe in the trench. Drain pipe failure could cause uneven wall settlement.
 - To prevent excessive interior humidity, install a backwater valve on the outlet drain pipe.
 - Crushed stone footings shall use ½" clean crushed stone, and consolidated using a vibratory plate in a maximum of 8-inch lifts.
 - When an exterior drainage pipe is used, an approved filter membrane material shall cover the pipe.
 - Slab connectors shall be bent into the concrete floor pour per detail.
 - To prevent air and water infiltration, cover the exposed stones on the exterior of the wall with backfill or patio construction, sloped away from the wall.

Figure 5b

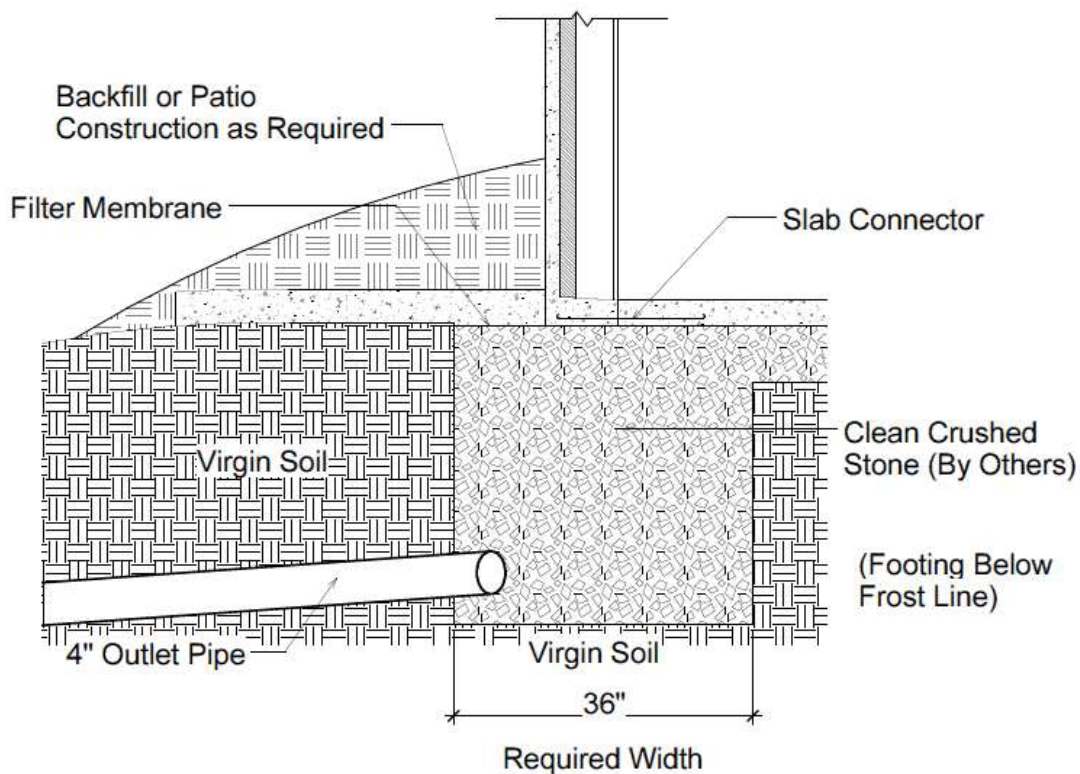

Using Crushed Stone Trench Footing for Basement/Above Grade Walls in Frost Areas

1. Figure 6 illustrates how to use crush stone trench footings.
2. General Requirements:
 - The bottom and both sides of the trench must be in virgin undisturbed soil
 - The trench must be 36" wide.
 - The bottom of the trench must extend below the local frost depth.
 - Using a drainage pipe per 2012 IRC Section R405, provide an outlet to daylight or to a sump pit with a pump.
 - Do NOT place a continuous pipe in the trench due to the possibility of wall settlement because of pipe crushing.
 - To prevent excessive interior humidity, install a backwater valve on the outlet drain pipe.
 - If slab connectors are provided, bend them into the concrete floor pour.
 - To prevent air and water infiltration, cover the exposed stones on the exterior of the wall with backfill or patio construction, sloped away from the wall.

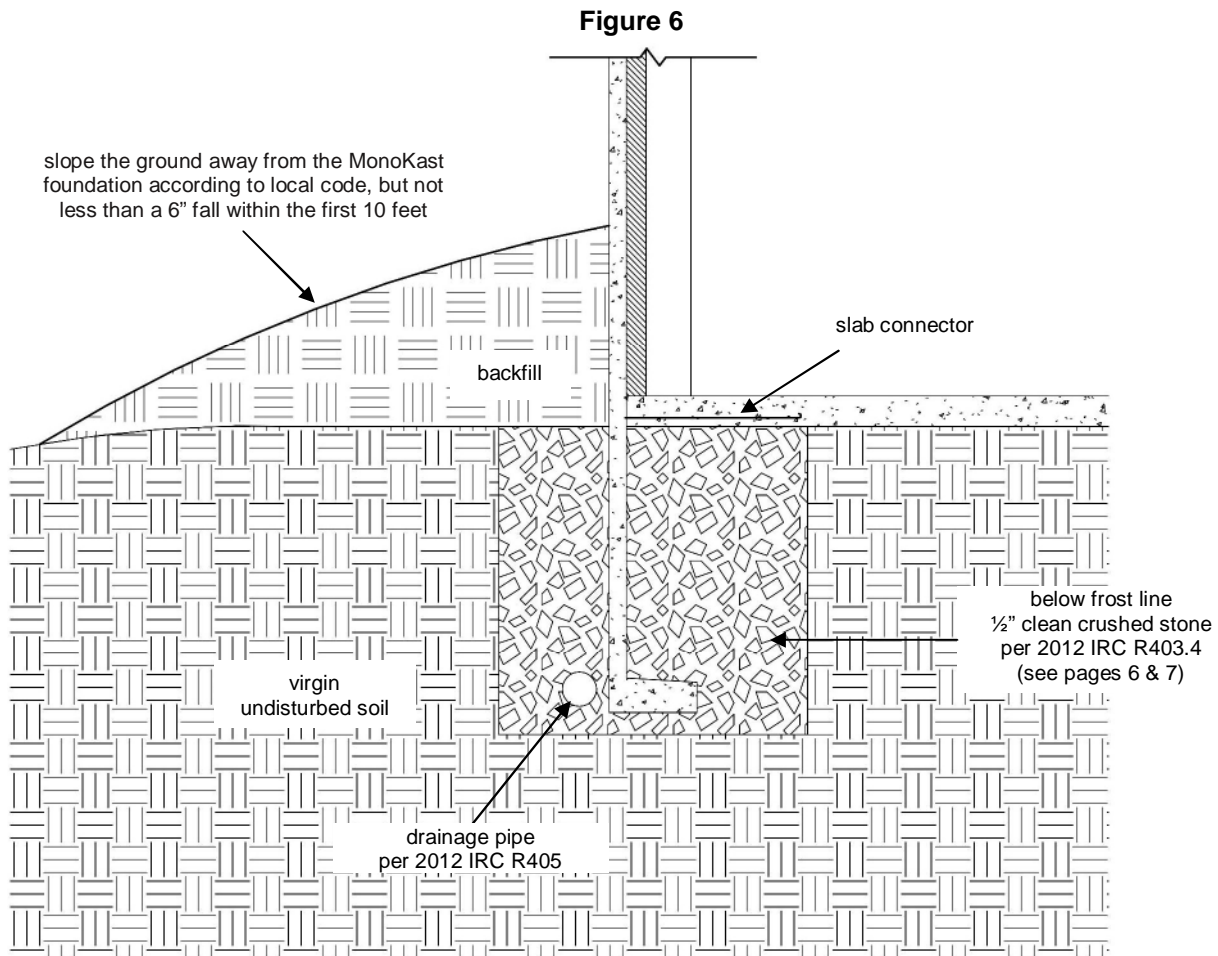

Using Crushed Stone Trench Footing for Basement/Above Grade Walls in Non-Frost/Shallow Frost Areas

1. The crushed stone trench footing must be on virgin/undisturbed soil.
2. The footing must extend at least 12" below the ground surface.
3. Place a 4" perforated drainage pipe at least one foot (12") beyond the nearest edge of the MonoKast Walls – on either the interior or exterior side of the MonoKast wall.
4. The drainage pipe should be directed to a sump pit or the daylight drain.
5. A filter membrane must be "approved." As defined in the 2012 IRC, must be "acceptable to the building official." Once approved, install the filter membrane.
6. If bend slab connectors are provided, bend them into the concrete floor pour.
7. To prevent air and water infiltration, cover the exposed stones on the exterior of the wall with backfill or patio construction, sloped away from the wall.
8. In certain conditions, such as an open floor plan or uneven backfill, a shear wall may be required. See page 37, "Determining the Need for a Shear Wall," for more information.

Code Reference: 2012 IRC Section: R403.1.4

R403.1.4 Minimum Depth. All exterior footings shall be placed at least 12 inches (305 mm) below the undisturbed ground surface. Where applicable, the depth of footings shall also conform to Sections R403.1.4.1 through R403.1.4.2.

Figure 7

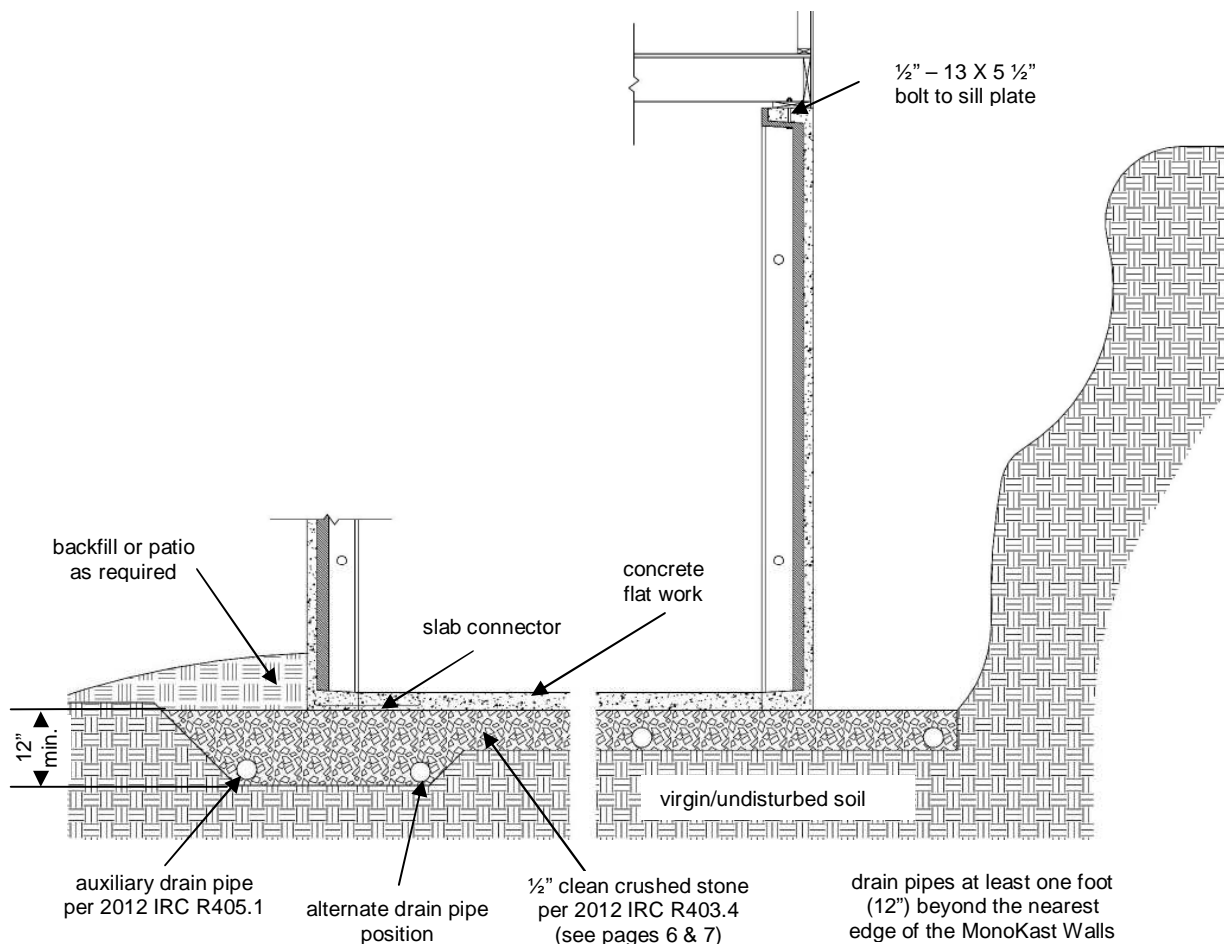

How to Pour the Concrete Floor

Code Reference: 2012 IRC Section: R506

SECTION R506 CONCRETE FLOORS (ON GROUND)

R506.1 General. Concrete slab-on-ground floors shall be designed and constructed in accordance with the provisions of this section or ACI 332. Floors shall be a minimum 3.5 inches (89 mm) thick (for expansive soils, see Section R403.1.8). The specified compressive strength of concrete shall be as set forth in Section R402.2.

R506.2 Site preparation. The area within the foundation walls shall have all vegetation, top soil and foreign material removed.

R506.2.1 Fill. Fill material shall be free of vegetation and foreign material. The fill shall be compacted to assure uniform support of the slab, and except where approved, the fill depths shall not exceed 24 inches (610 mm) for clean sand or gravel and 8 inches (203 mm) for earth.

R506.2.2 Base. A 4-inch-thick (102 mm) base course consisting of clean graded sand, gravel, crushed stone or crushed blast-furnace slag passing a 2-inch (51 mm) sieve shall be placed on the prepared subgrade when the slab is below grade.

Exception: A base course is not required when the concrete slab is installed on well-drained or sand-gravel mixture soils classified as Group I according to the United Soil Classification System in accordance with Table R405.1.

R506.2.3 Vapor retarder. A 6-mil (0.006 inch; 152 mm) polyethylene or approved vapor retarder with joints lapped not less than 6 inches (152 mm) shall be placed between the concrete floor slab and the base course or the prepared subgrade where no base course exists.

Exception: The vapor retarder may be omitted:

1. From garages, utility buildings and other unheated accessory structures.
2. For unheated storage rooms having an area of less than 70 square feet (6.5 m²) and carports.
3. From driveways, walks, patios and other flatwork not likely to be enclosed and heated at a later date.
4. Where approved by the building official, based on local site conditions.

R506.2.4 Reinforcement support. Where provided in slabs on ground, reinforcement shall be supported to remain in place from the center to upper one third of the slab for the duration of the concrete placement.

Floor Pour

1. If slab connectors are provided, bend them into the floor pour.
2. A screed board is not necessary with MonoKast 3.5" footers
3. Maintain precast bevel on top edge of MonoKast footer when pouring concrete floor (See Figure 8 below).
4. For an insulated slab edge procedure, please contact your MonoKast representative.

Figure 8

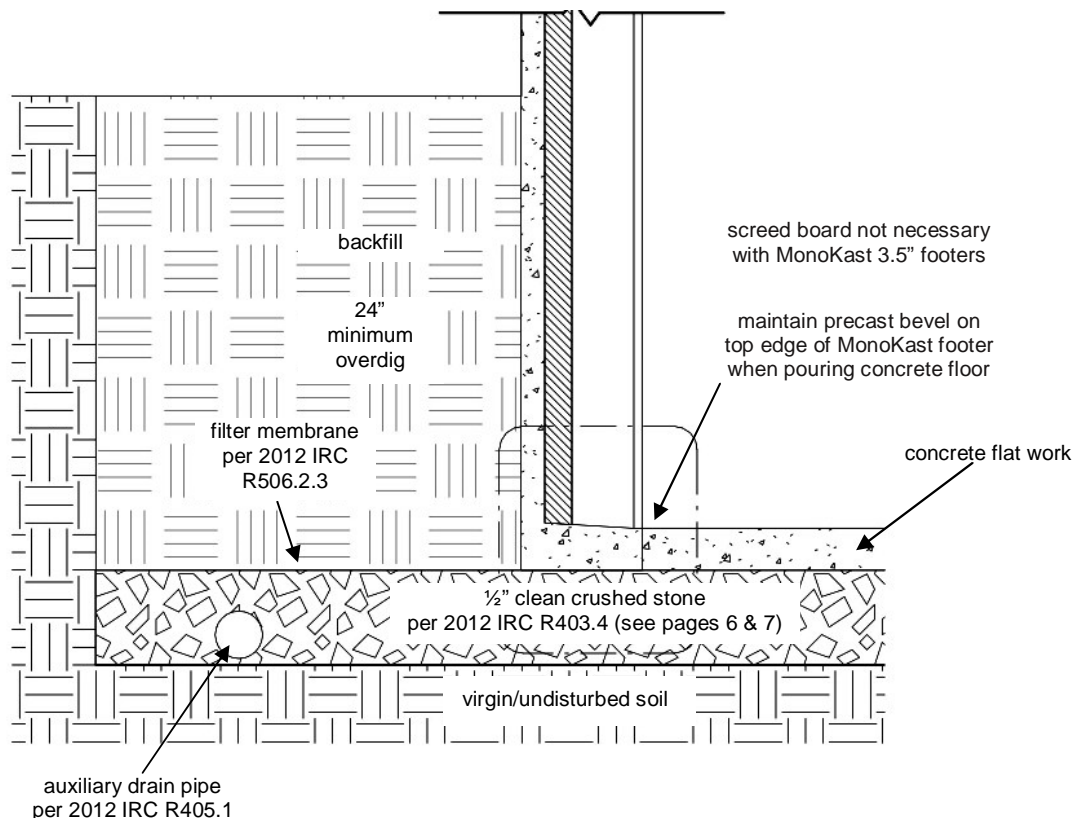

Pouring a Raised Floor

To pour a basement floor at an elevation higher than the typical 2' elevation:

Option 1 (Figure 9):

- Cut and remove the foam insulation below the desired floor surface.
- Cut and remove the interior stud facing below the desired floor surface.

Option 2 (Figure 9):

- Leave the foam insulation and the interior stud facing on the MonoKast panel and the pour concrete floor. Allow direct contact between the MonoKast footer beam and the concrete floor pour.

Code Reference: 2012 IRC Section: R318.4

R318.4 Foam plastic protection. In areas where the probability of termite infestation is "very heavy" as indicated in figure R301.2(6), extruded and expanded polystyrene, polyisocyanurate and other foam plastics shall not be installed on the exterior face or under interior or exterior foundations walls or slab foundations located below *grade*. The clearance between foam plastics installed above *grade* and exposed earth shall be at least 6 inches (152 mm)

Exceptions:

- Buildings where the structural members of walls, floors, ceilings and roofs are entirely of noncombustible materials or pressure-preservative-treated wood.
- When in *addition* to the requirements of R318.1, an *approved* method of protecting the foam plastic and structure from subterranean termite damage is provided.

6. On the interior side of basement walls.

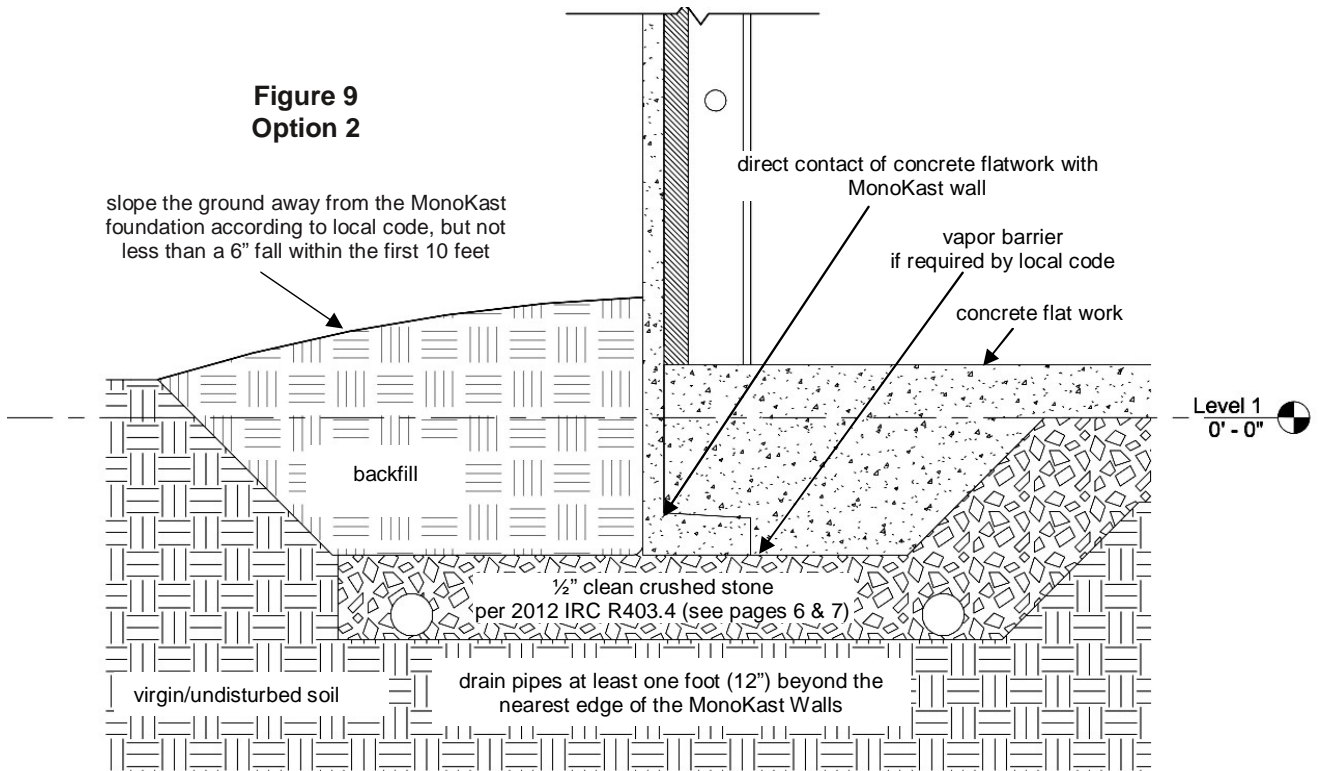
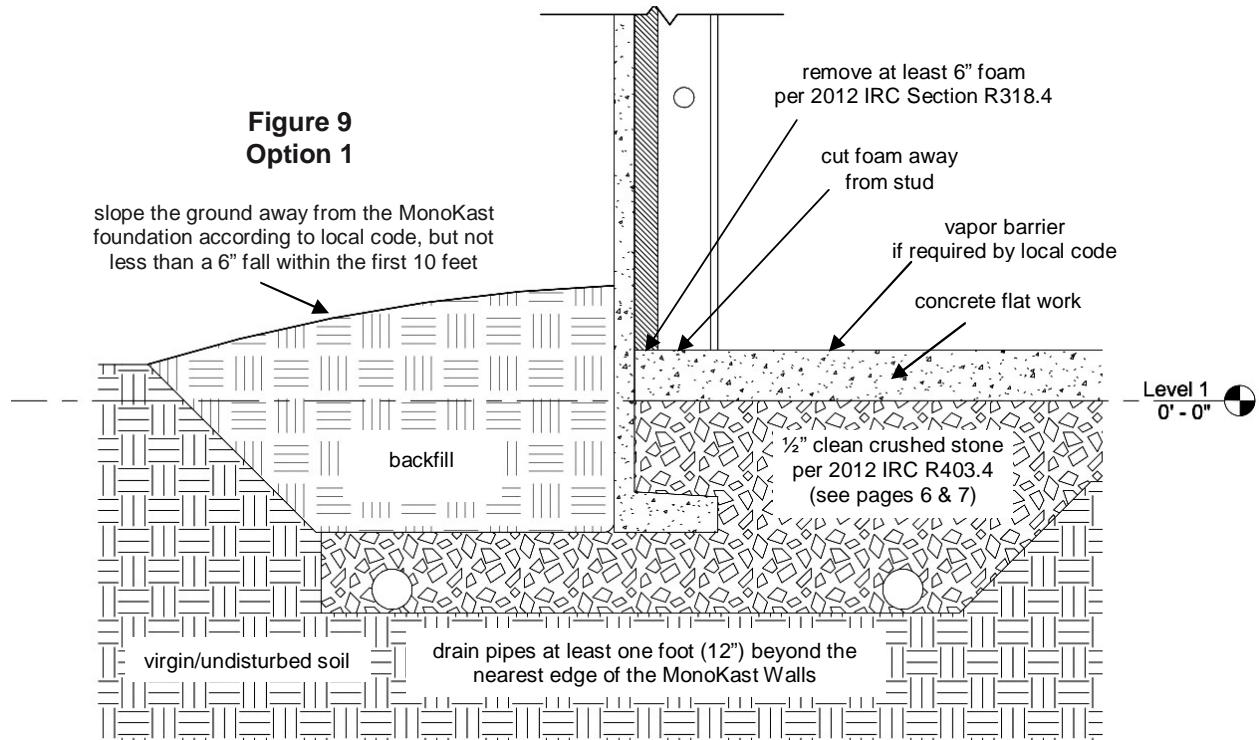

Crawl Spaces

Code Reference: 2012 IRC Section: R408

R408 UNDER-FLOOR SPACE.

R408.1 Ventilation. The under-floor space between the bottom of the floor joists and the earth under any building (except space occupied by a basement) shall have ventilation openings through foundation walls or exterior walls. The minimum net area of ventilation openings shall not be less than 1 square foot (0.0929 m²) for each 150 square feet (14 m²) of under-floor space area, unless the ground surface is covered by a Class 1 vapor retarder material. When a Class 1 vapor retarder material is used, the minimum net area of ventilation openings shall not be less than 1 square foot (0.0929 m²) for each 1,500 square feet (140 m²) of under-floor space area. One such ventilating opening shall be within 3 feet (914 mm) of each corner of the building.

R408.2 Openings for under-floor ventilation. The minimum net area of ventilation openings shall not be less than 1 square foot (0.0929 m²) for each 150 square feet (14 m²) of under-floor area. One ventilation opening shall be within 3 feet (915 mm) of each corner of the building. Ventilation openings shall be covered for their height and width with any of the following materials provided that the least dimension of the covering shall not exceed 1/4 inch (6.4 mm):

1. Perforated sheet metal plates not less than 0.070 inch (1.8 mm) thick.
2. Expanded sheet metal plates not less than 0.047 inch (1.2 mm) thick.
3. Cast-iron grill or grating.
4. Extruded load-bearing brick vents.
5. Hardware cloth of 0.035 inch (0.89 mm) wire or heavier.
6. Corrosion-resistant wire mesh, with the least dimension being 1/8 inch (3.2 mm) thick.

Exception: The total area of ventilation openings shall be permitted to be reduced to 1/1,500 of the under-floor area where the ground surface is covered with an approved Class I vapor retarder material and the required openings are placed to provide cross ventilation of the space. The installation of operable louvers shall not be prohibited.

R408.3 Unvented crawl space. Ventilation openings in under-floor spaces specified in Sections R408.1 and R408.2 shall not be required where:

1. Exposed earth is covered with a continuous Class I vapor retarder. Joints of the vapor retarder shall overlap by 6 inches (152 mm) and shall be sealed or taped. The edges of the vapor retarder shall extend at least 6 inches (152 mm) up the stem wall and shall be attached and sealed to the stem wall or insulation; and
2. One of the following is provided for the under-floor space:
 - 2.1. Continuously operated mechanical exhaust ventilation at a rate equal to 1 cubic foot per minute (0.47 L/s) for each 50 square feet (4.7 m²) of crawlspace floor area, including an air pathway to the common area (such as a duct or transfer grille), and perimeter walls insulated in accordance with Section N1103.2.1 of this code;
 - 2.2. Conditioned air supply sized to deliver at a rate equal to 1 cubic foot per minute (0.47 L/s) for each 50 square feet (4.7 m²) of under-floor area, including a return air pathway to the common area (such as a duct or transfer grille), and perimeter walls insulated in accordance with Section N1102.2 of this code;
 - 2.3. Plenum in existing structures complying with Section M1601.5, if under-floor space is used as a plenum.

R408.4 Access. Access shall be provided to all under-floor spaces. Access openings through the floor shall be a minimum of 18 inches by 24 inches (457 mm by 610 mm). Openings through a perimeter wall shall be not less than 16 inches by 24 inches (407 mm by 610 mm). When any portion of the through-wall access is below grade, an areaway not less than 16 inches by 24 inches (407 mm by 610 mm) shall be provided. The bottom of the areaway shall be below the threshold of the access opening. Through wall access openings shall not be located under a door to the residence. See Section M1305.1.4 for access requirements where mechanical equipment is located under floors.

R408.5 Removal of debris. The under-floor grade shall be cleaned of all vegetation and organic material. All wood forms used for placing concrete shall be removed before a building is occupied or used for any purpose. All construction materials shall be removed before a building is occupied or used for any purpose.

R408.6 Finished grade. The finished grade of under-floor surface may be located at the bottom of the footings; however, where there is evidence that the groundwater table can rise to within 6 inches (152 mm) of the finished floor at the building perimeter or where there is evidence that the surface water does not readily drain from the building site, the grade in the under-floor space shall be as high as the outside finished grade, unless an approved drainage system is provided.

R408.7 Flood resistance. For buildings located in flood hazard areas as established in Table R301.2 (1):

1. Walls enclosing the under-floor space shall be provided with flood openings in accordance with Section R322.2.2.
2. The finished ground level of the under-floor space shall be equal to or higher than the outside finished ground level on at least one side.

Exception: Under-floor spaces that meet the requirements of FEMA/FIA TB 11-1.

With Wood Bracing

1. Use construction adhesive between the bond beam and the sill plate.
2. Use 2x10 treated sill plate.
3. Use two washers (one above the wood sill plate and one between the nut and the underside of the bond beam) to bolt the sill plate with minimum $\frac{1}{2}$ " – 13 x 5- $\frac{1}{2}$ " bolts through the precast holes in the top bond beam.
4. Bolt the sill plate within 12" of the end of all plate sections, per 2012 IRC R403.1.6 (page 22)
5. The sill plate splices must be at least 4 feet from any MonoKast foundation panel joint.
6. Use clamps to temporarily secure the sill plate's position prior to bolting. (Nails or other methods may crack the concrete.)

Figure 10

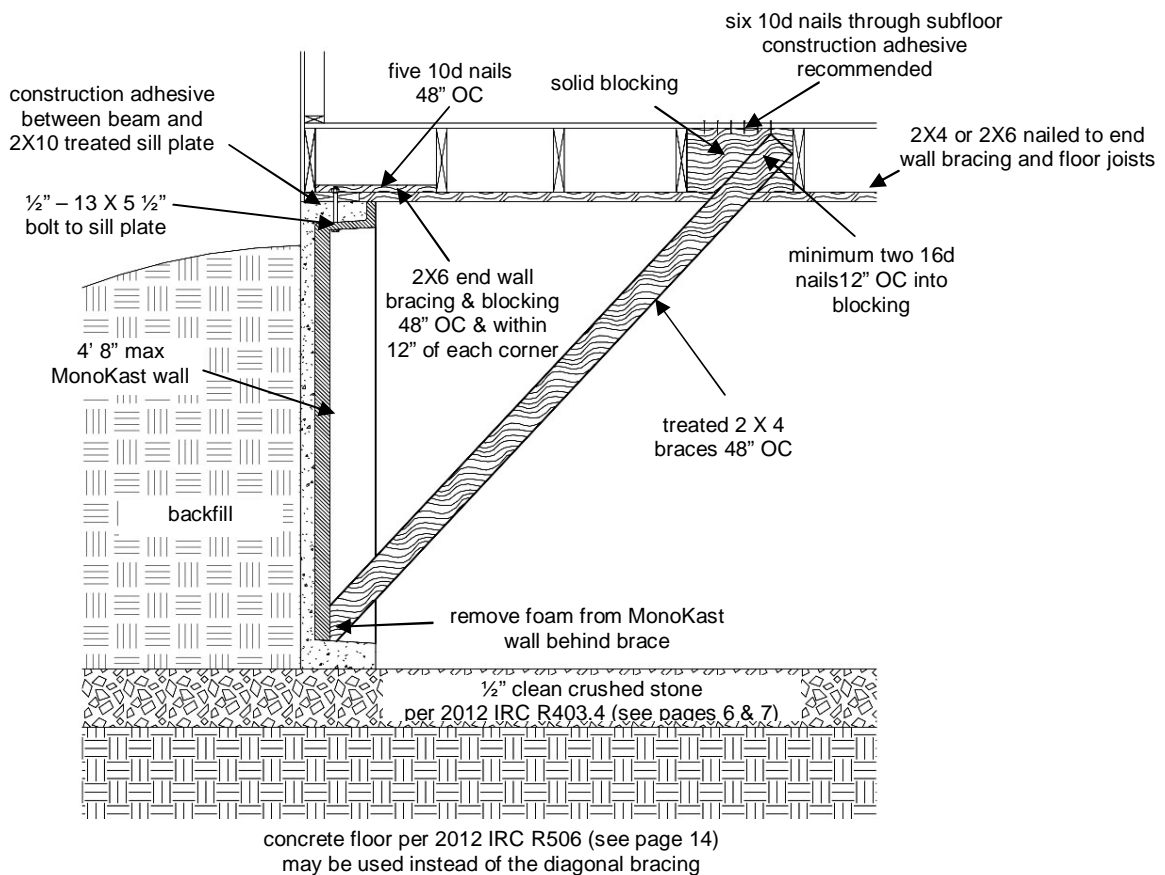

Without Wood Bracing

1. To secure the bottom of the wall, fill the inside and outside simultaneously.
2. If the frost wall is below the frost line, a perimeter drainage pipe is not required.

Code Reference: 2012 IRC Section: R318.4

R318.4 Foam plastic protection. In areas where the probability of termite infestation is “very heavy” as indicated in figure R301.2(6), extruded and expanded polystyrene, polyisocyanurate and other foam plastics shall not be installed on the exterior face or under interior or exterior foundations walls or slab foundations located below grade. The clearance between foam plastics installed above *grade* and exposed earth shall be at least 6 inches (152 mm).

Exceptions:

1. Buildings where the structural members of walls, floors, ceilings and roofs are entirely of noncombustible materials or pressure-preservative-treated wood.
2. When in addition to the requirements of R318.1, an approved method of protecting the foam plastic and structure from subterranean termite damage is provided.
3. On the interior side of basement walls.

Figure 11

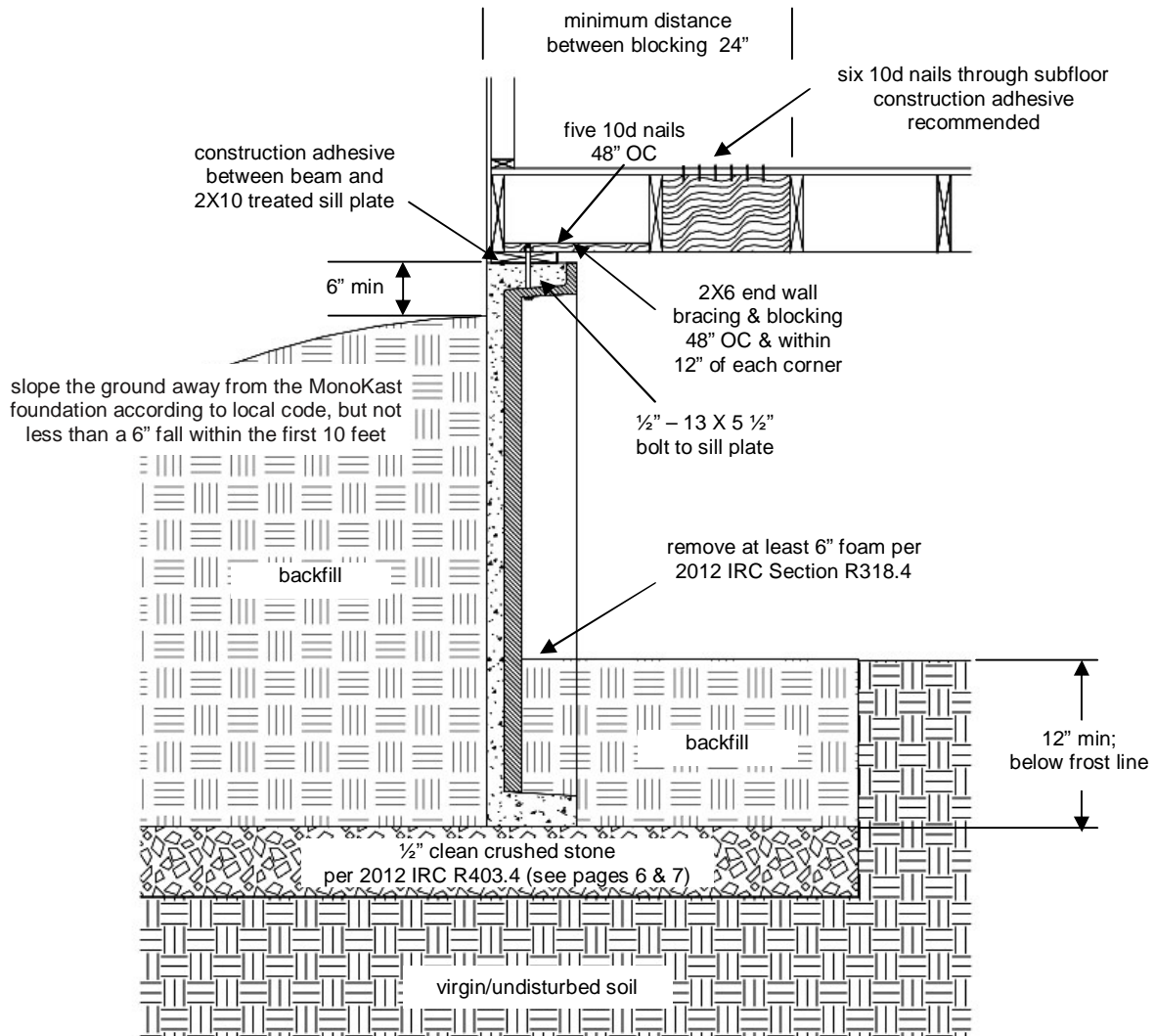

Additional Inside Fill Conditions

For other inside fill settings, such as porches or garages:

1. The maximum backfill differential is 36".
2. If your project requires backfill differential greater than 36", discuss additional reinforcement with your MonoKast representative prior to panel manufacturing.
3. MonoKast recommends stone for infill
4. Fasten (using washers and nuts) a ½" all-thread rod every 24" through the precast holes in the bond beam.
5. The rod should be parallel to the floor pour and centered in the concrete.
6. The rod should extend at least 24" beyond the inside edge of the bond beam.
7. Apply temporary bracing on the wall exterior until concrete floor is poured and cured.
8. Restrain the bottom of the wall to resist the lateral pressure of the infill material.

Figure 12

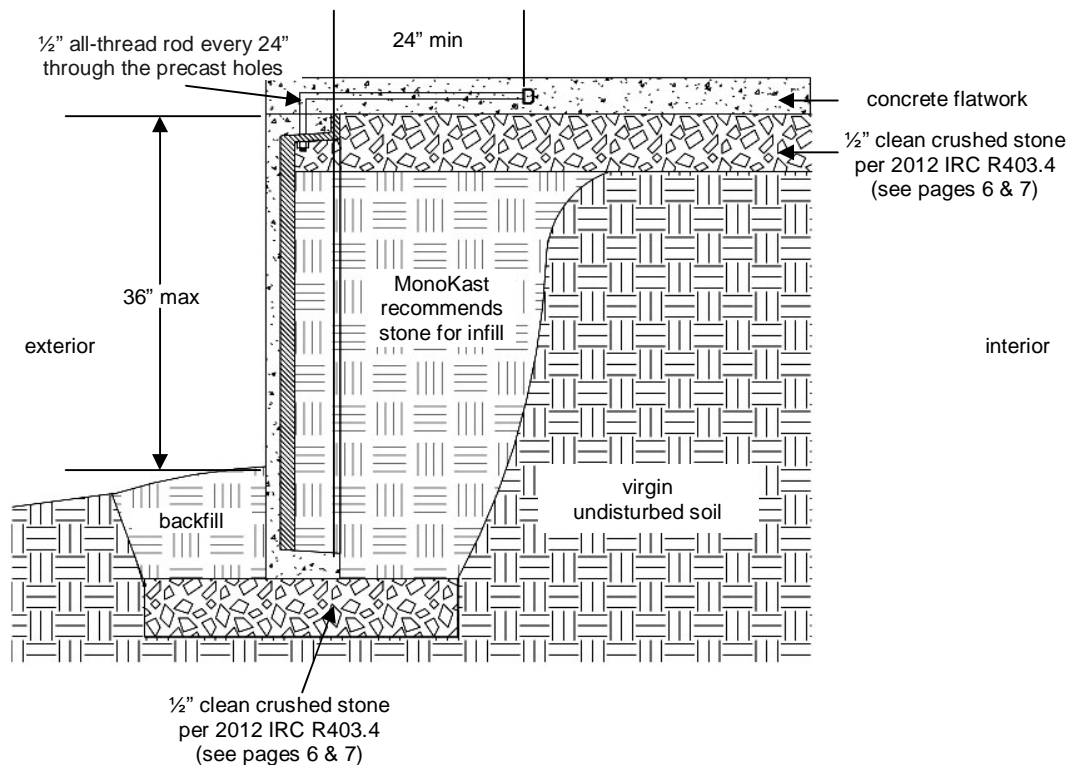

Garage Frost Walls

1. Figure 13 illustrates wall types typically used for garage frost walls.
2. For frost wall applications that are below the frost line, a perimeter drainage pipe is not required.

Figure 13

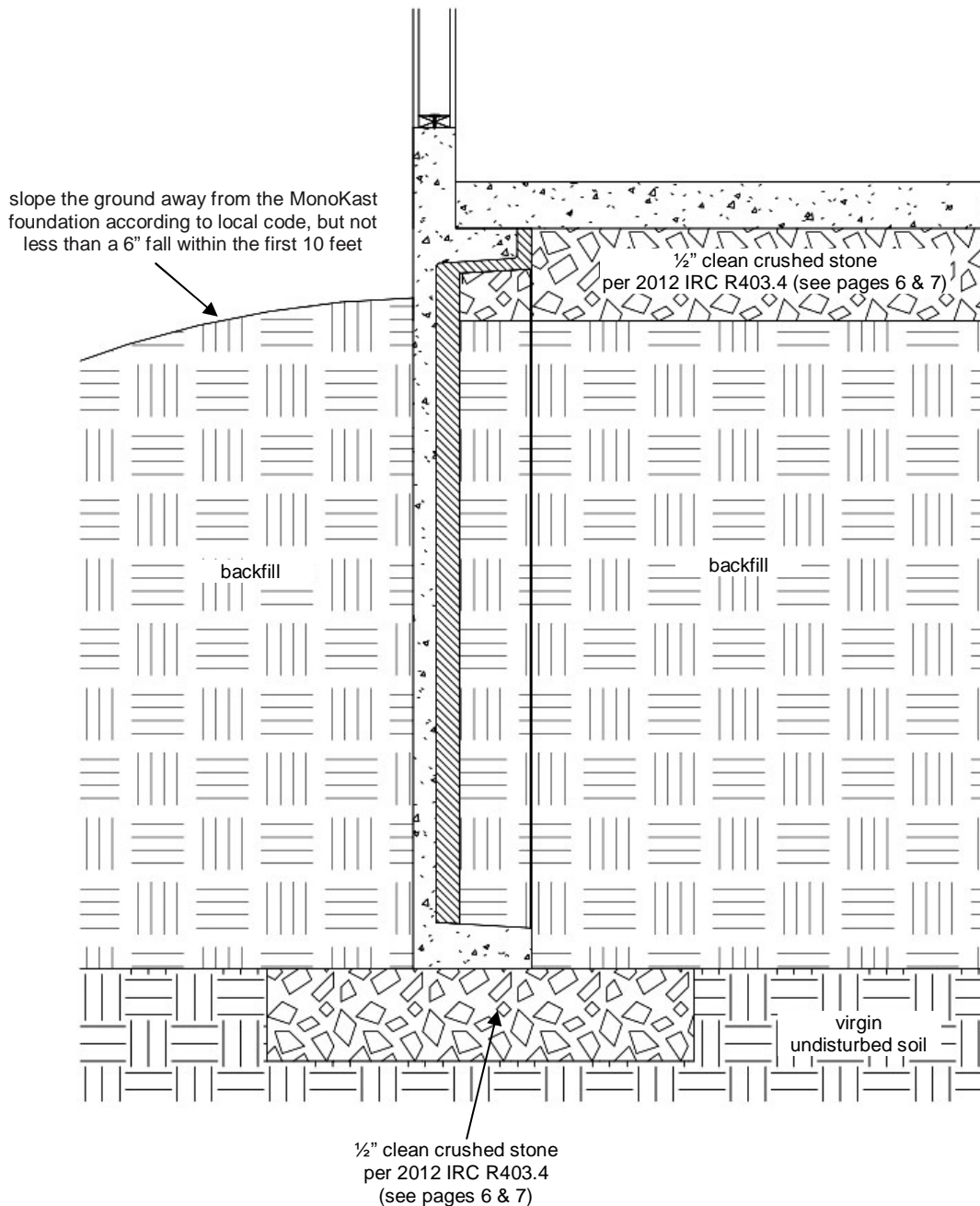

Framing Connections

Notes:

1. Building code requires that the framing/decking connection at the top of the MonoKast panel and the floor slab at the bottom of the MonoKast panel must both be completed prior to backfilling.
2. Pressure-treated lumber requires special fastener considerations, per code reference R317.3.1.

Sill Plate

7. MonoKast recommends construction adhesive between the bond beam and the sill plate.
8. Use 2x10 treated sill plate.
9. **MonoKast requires use of 1/2" – 13 X 5 1/2" bolt to sill plate 24" on center** with two washers (one above the wood sill plate and one between the nut and the underside of the bond beam) to bolt the sill through the precast holes in the top bond beam
10. Bolt the sill plate within 12" of the end of all plate sections, per 2012 IRC R403.1.6
11. The sill plate splices must be at least 4 feet from any MonoKast panel joint.
12. Use clamps to temporarily secure the sill plate's position prior to bolting. (Nails or other methods may crack the concrete.)

Code Reference: 2012 IRC Section: R404.1.7

R404.1.7 Backfill placement. Backfill shall not be placed against the wall until the wall has sufficient strength and has been anchored to the floor above, or has been sufficiently braced to prevent damage by backfill.

Exception: Such bracing is not required for walls supporting less than 4 feet (1219 mm) of unbalanced backfill.

Code Reference: 2012 IRC Section: R403.1.6

R403.1.6 Foundation anchorage.

...wood sill plate shall be anchored to the foundation with anchor bolts spaced a maximum of 6 feet (1829 mm) on center...Bolts shall be at least 1/2 inch (12.7 mm) in diameter ...A nut and washer shall be tightened on each bolt to the plate...There shall be a minimum of two bolts per plate section with one bolt located not more than 12 inches (305 mm) or less than seven bolt diameters from each end of the plate section.

Exceptions:

1. Foundation anchorage, spaced as required to provide equivalent anchorage to 1/2-inch-diameter (12.7 mm) anchor bolts.
2. Walls 24 inches (610 mm) total length or shorter connecting offset braced wall panels shall be anchored to the foundation with a minimum of one anchor bolt located in the center third of the plate section and shall be attached to adjacent braced wall panels at corners as shown in item 8 of Table R602.3(1).
3. Connection of walls 12 inches (305 mm) total length or shorter connecting offset braced wall panels to the foundation without anchor bolts shall be permitted. The wall shall be attached to adjacent braced wall panels at corners as shown in item 8 of Table R602.3 (1).

Code Reference: 2012 IRC Section: R317.3.1

R317.3.1 Fasteners for preservative- treated wood. Fasteners, including nuts and washers, for preservative-treated wood shall be of hot dipped, zinc-coated galvanized steel, stainless steel, silicon bronze or copper. Coating types and weights for connectors in contact with preservative-treated wood shall be in accordance with the connector manufacturer's recommendations...

Exceptions:

1. One-half-inch-diameter (12.7 mm) or greater steel bolts.
2. Fasteners other than nails and timber rivets shall be permitted to be of mechanically deposited zinc-coated steel with coating weights in accordance with ASTM B 695, Class 55 minimum.
3. Plain carbon steel fasteners in SBX/DOT and zinc borate preservative-treated wood in an interior, dry environment shall be permitted.

Table 4 FASTENER SCHEDULE FOR STRUCTURAL MEMBERS			
Table Reference: 2012 IRC TABLE R602.3(1)			
ITEM	DESCRIPTION OF BUILDING ELEMENTS	NUMBER AND TYPE OF FASTENER ^{a, b, c}	SPACING OF FASTENERS
Wall			
7	Built-up studs-face nail	10d (3" x 0.128")	24" o.c.
8	Abutting studs at intersecting wall corners, face nail	16d (3 1/2" x 0.135")	12" o.c.
9	Built-up header, two pieces with 1/2" spacer	16d (3 1/2" x 0.135")	16" o.c. along each edge
10	Continued header, two pieces	16d (3 1/2" x 0.135")	16" o.c. along each edge
11	Continuous header to stud, toe nail	4-8d (2 1/2" x 0.113")	-
12	Double studs, face nail	10d (3" x 0.128")	24" o.c.
13	Double top plates, face nail	10d (3" x 0.128")	24" o.c.
14	Double top plates, minimum 24-inch offset of end joints, face nail in lapped area	8 - 16d (3 1/2" x 0.135")	-
15	Sole plate to joist or blocking, face nail	16d (3 1/2" x 0.135")	16" o.c.
16	Sole plate to joist or blocking at braced wall panels	3 - 16d (3 1/2" x 0.135")	16" o.c.
17	Stud to sole plate, toe nail	3 - 8d (2 1/2" x 0.113") or 2 - 16d (3 1/2" x 0.135")	- -
18	Top or sole plate to stud, end nail	2 - 16d (3 1/2" x 0.135")	-
19	Top plates, laps at corners and intersections, face nail	2 - 10d (3" x 0.128")	-
20	1" brace to each stud and plate, face nail	2 - 8d (2 1/2" x 0.113")	-
21	1" x 6" sheathing to each bearing, face nail	2 - 8d (2 1/2" x 0.113")	-
22	1" x 8" sheathing to each bearing, face nail	2 - 8d (2 1/2" x 0.113")	-
23	Wider than 1" x 8" sheathing to each bearing, face nail	3 - 8d (2 1/2" x 0.113")	-
Floor			
24	Joist to sill or girder, toe nail	3 - 8d (2 1/2" x 0.113")	-
25	Rim joist to top plate, toe nail (roof applications also)	8d (2 1/2" x 0.113")	16" o.c.
26	Rim joist or blocking to sill plate, toe nail	8d (2 1/2" x 0.113")	16" o.c.
27	1" x 6" subfloor or less to each joist, face nail	2 - 8d (2 1/2" x 0.113")	-
28	2" subfloor to joist or girder, blind and face nail	2 - 16d (3 1/2" x 0.135")	-
29	2" planks (plank & beam - floor & roof)	2 - 16d (3 1/2" x 0.135")	at each bearing
30	Built-up girders and beams, 2-inch lumber layers	10d (3" x 0.128")	Nail each layer as follows: 32" o.c. at top and bottom and staggered. Two nails at ends and at each splice.
31	Ledger strip supporting joists or rafters	3 - 16d (3 1/2" x 0.135")	At each joist or rafter

Joists Perpendicular to MonoKast Panels

- 1. Nail each joist securely to sill plate according to code (minimum two 16d nails, 12" OC)

Figure 14

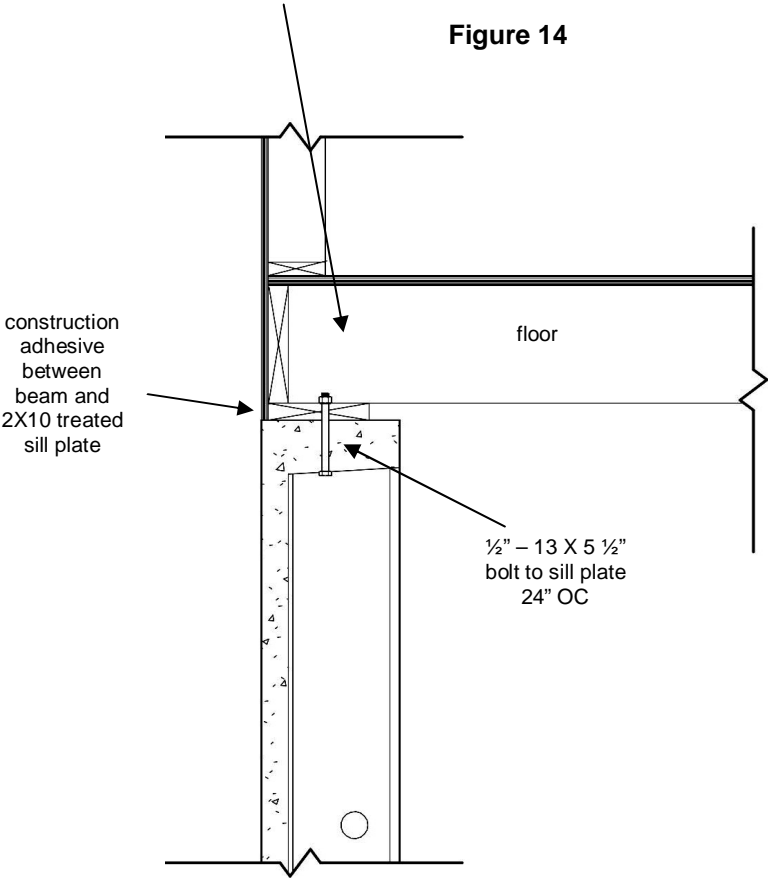

The information in this manual is confidential and may be legally privileged. It is intended solely for the use of MonoKast Precast Concrete Wall Systems, LLC, its licensees and authorized customers. If you are not the intended recipient, any disclosure, copying, distribution or any action taken or omitted to be taken in reliance on this manual, is prohibited and may be unlawful.

Joists Perpendicular to MonoKast Panels (cont.)

Figure 15

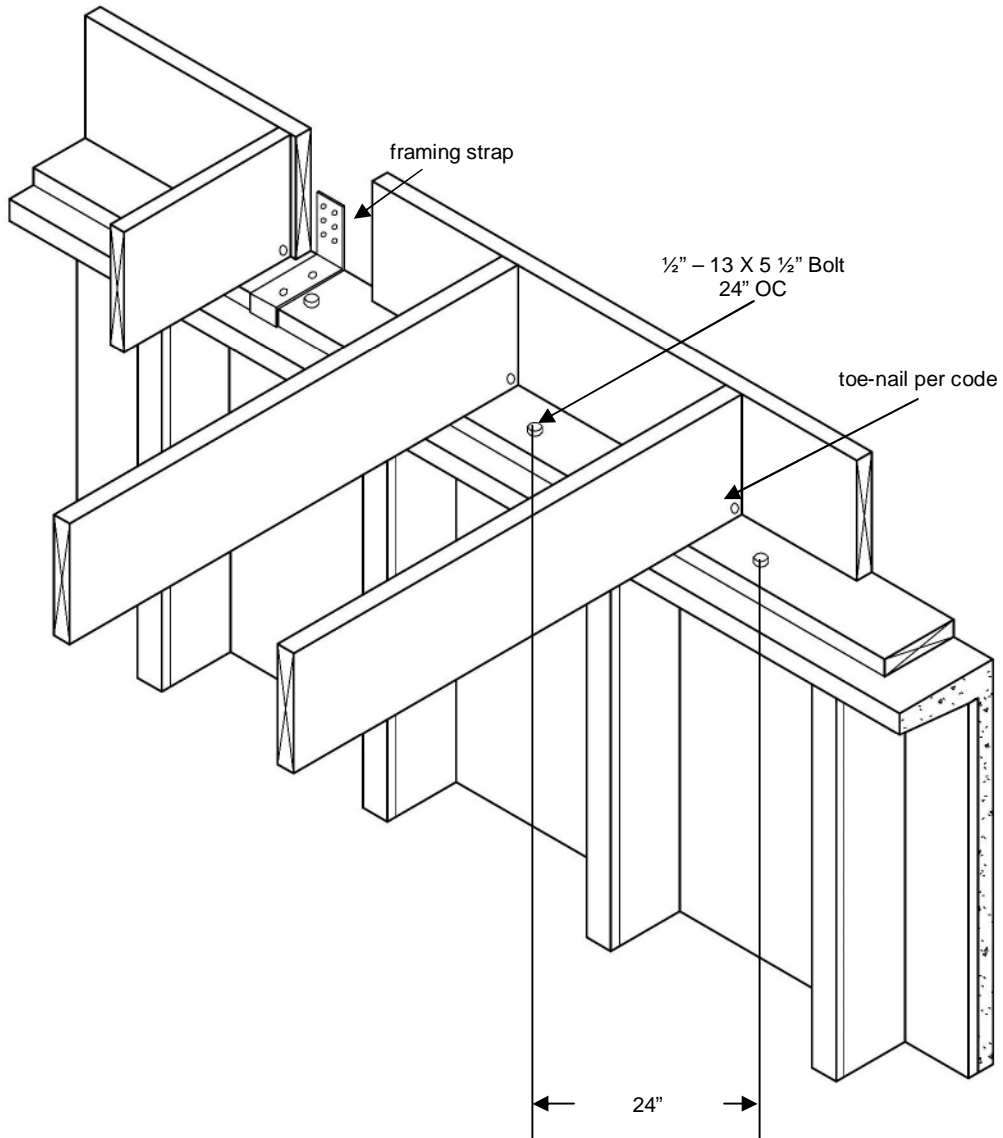

Joists Parallel to MonoKast Panels

1. **Use five 10d nails every 48" on center** to nail a 2 x 6 end wall brace securely to the sill plate.
2. The end wall brace must be within 12" from each corner interior.
3. If backfill is less than 7'-6", use 1 solid block. Nail the block in line with the 2 x 6 end wall brace
4. If backfill is between 7'-6" and 9'-6" for joists less than 10', use 2 solid blocks.
5. Use 3 solid blocks for joists 10' or more, when backfill is between 7'-6" and 9'-6"
6. For "I" Joist construction, see Figure 22 on page 30.

Figure 16

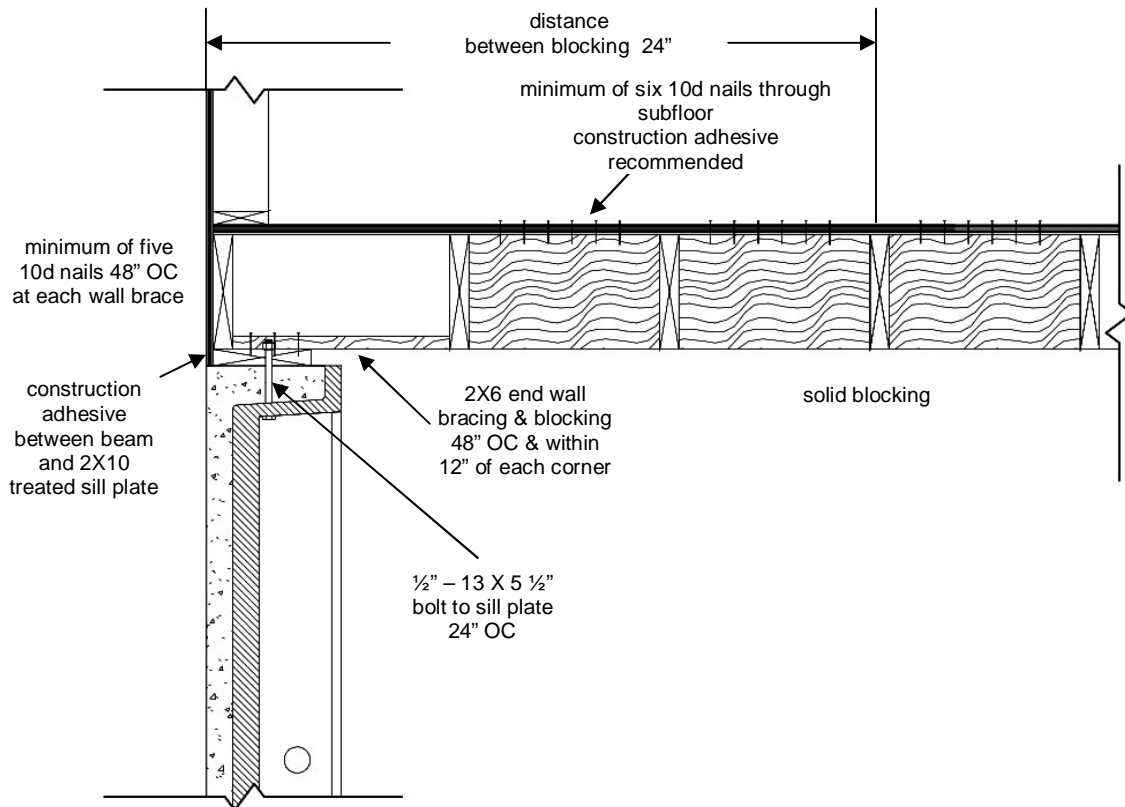

Joists Parallel to MonoKast Panels (cont.)

1. **Use five 10d nails every 48" on center** to nail a 2 x 6 end wall brace securely to the sill plate.
2. The end wall brace must be within 12" from each corner interior.
3. Use a minimum of six 10d nails through subfloor; construction adhesive recommended

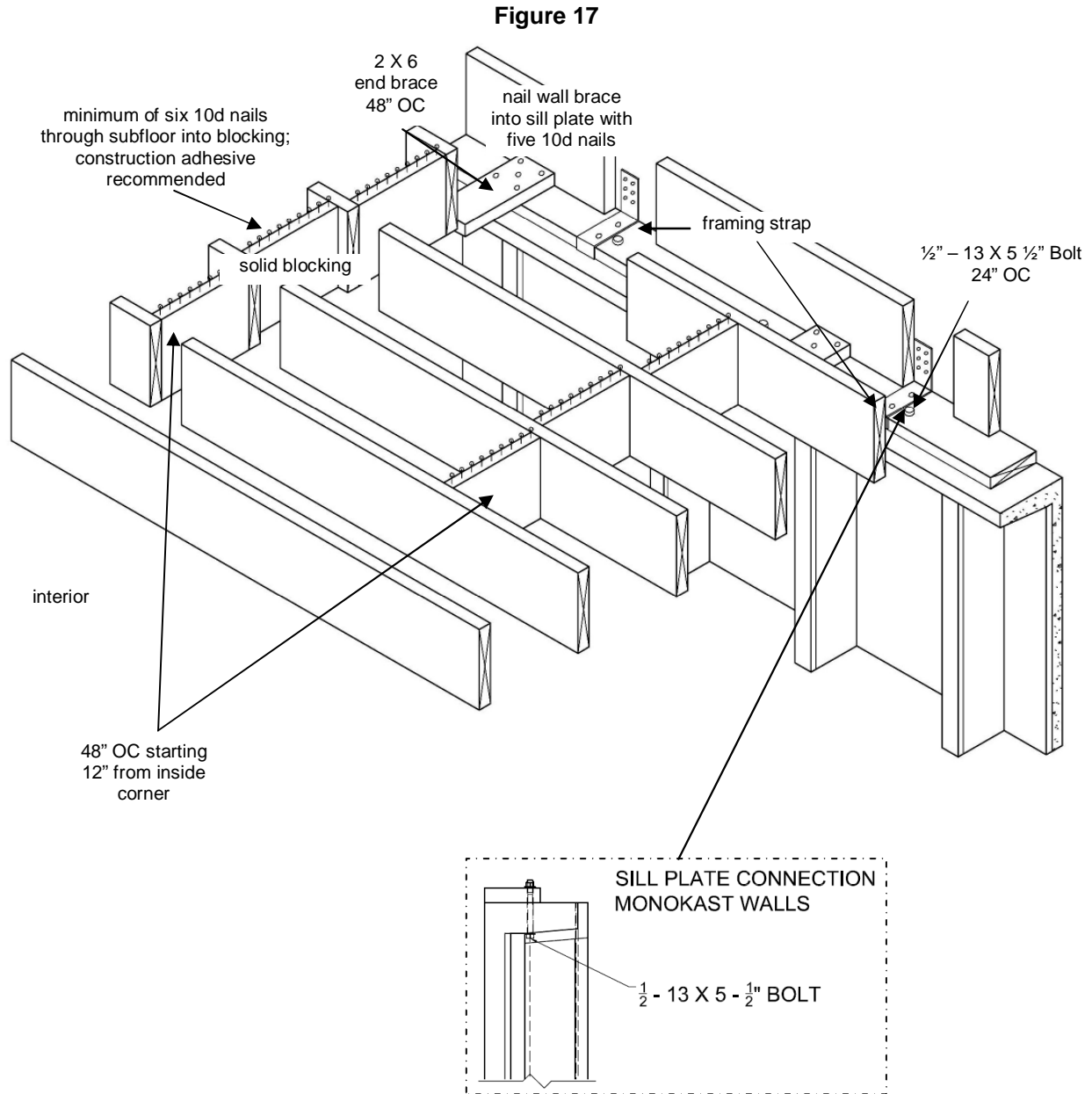

Joists Parallel to MonoKast Panels (cont.)

1. Additional blocking is required if HVAC ductwork is located where solid blocking is shown in Figure 16 (page 25) and Figure 17 (page 26).
2. 2x6 Flat Blocking will replace solid blocking between the joists and in line with the end wall brace.
3. To replace the solid blocking that was removed for the HVAC ductwork, add solid blocking to the next open joist bay.
4. If backfill is less than 7'-6", use 1 solid block. Nail the block in line with the 2 x 6 end wall brace
5. If backfill is between 7'-6" and 9'-6" for joists less than 10', use 2 solid blocks.
6. Use 3 solid blocks for joists 10' or more, when backfill is between 7'-6" and 9'-6"

Figure 18

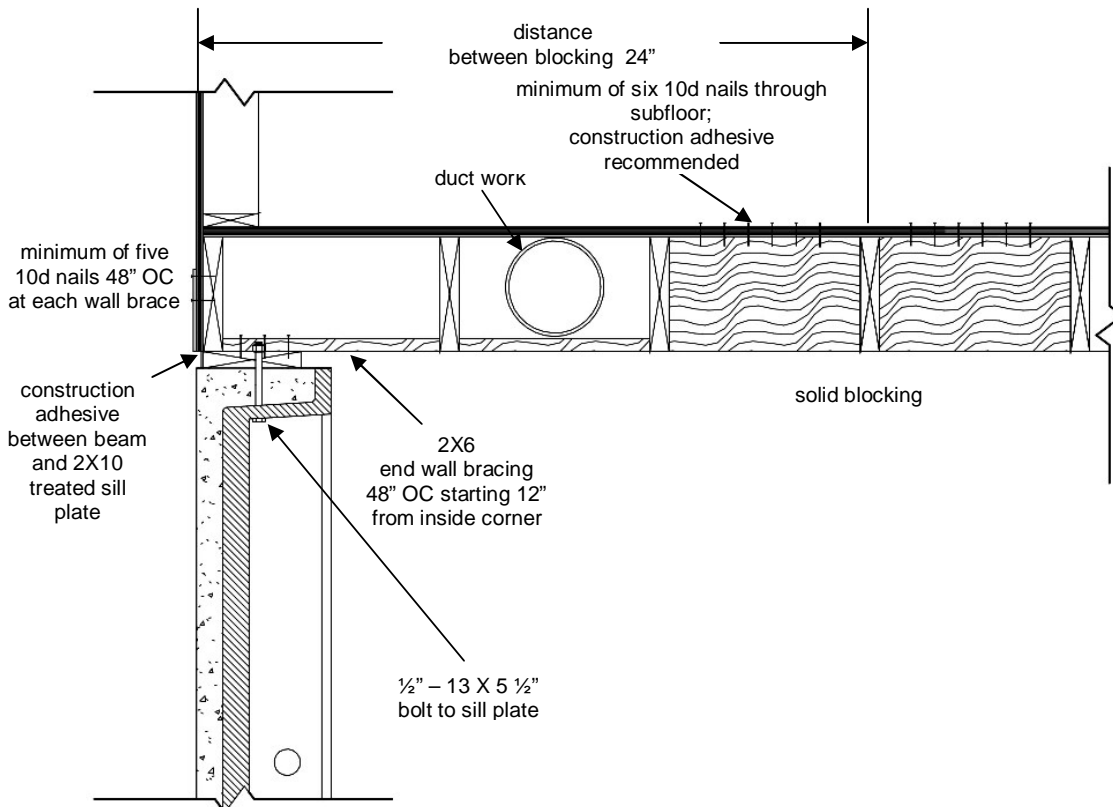

"I" Joist Blocking Detail

Figure 19

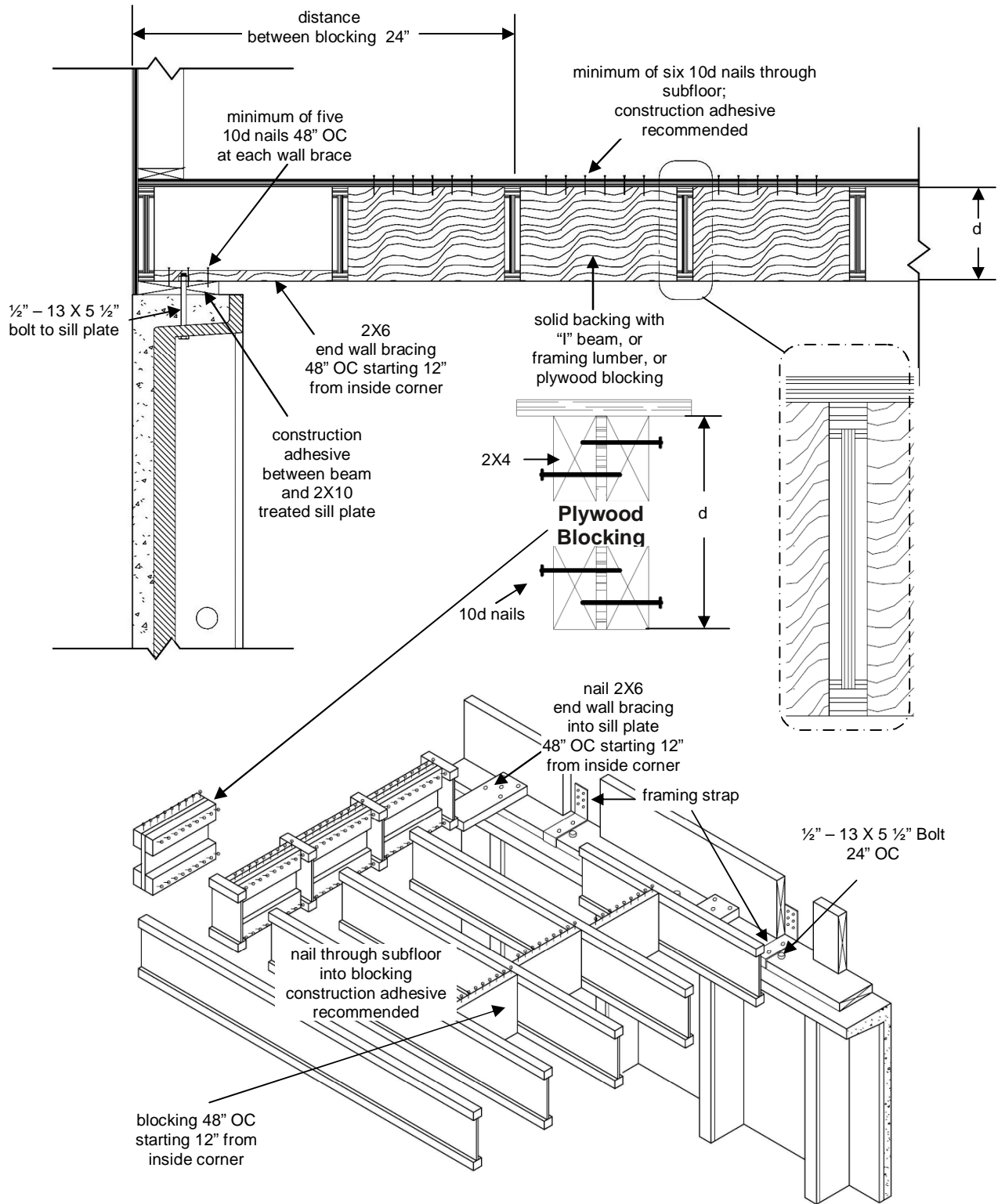

Top Chord Bearing Open Floor Truss

Open Floor Truss Perpendicular to MonoKast Panel

Figure 20

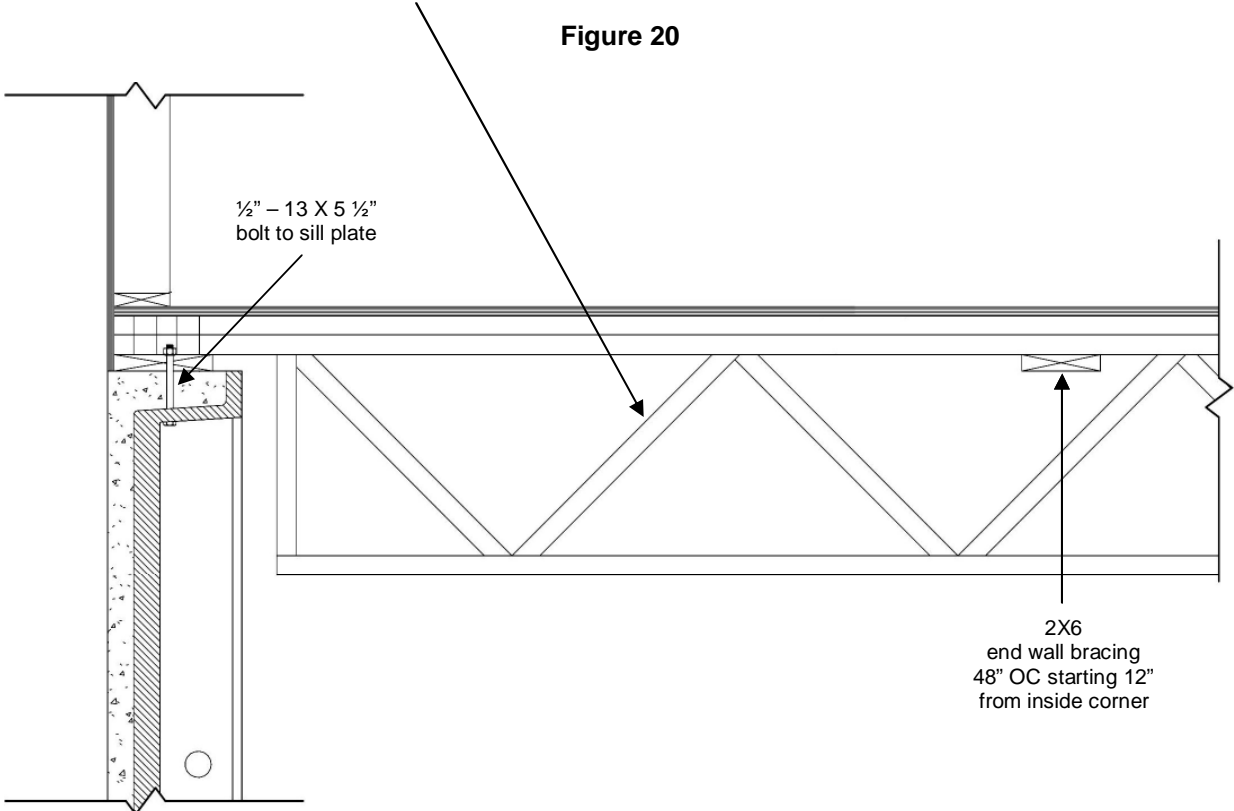

The information in this manual is confidential and may be legally privileged. It is intended solely for the use of MonoKast Precast Concrete Wall Systems, LLC, its licensees and authorized customers. If you are not the intended recipient, any disclosure, copying, distribution or any action taken or omitted to be taken in reliance on this manual, is prohibited and may be unlawful.

Open Floor Truss Parallel to MonoKast Panel

Figure 21

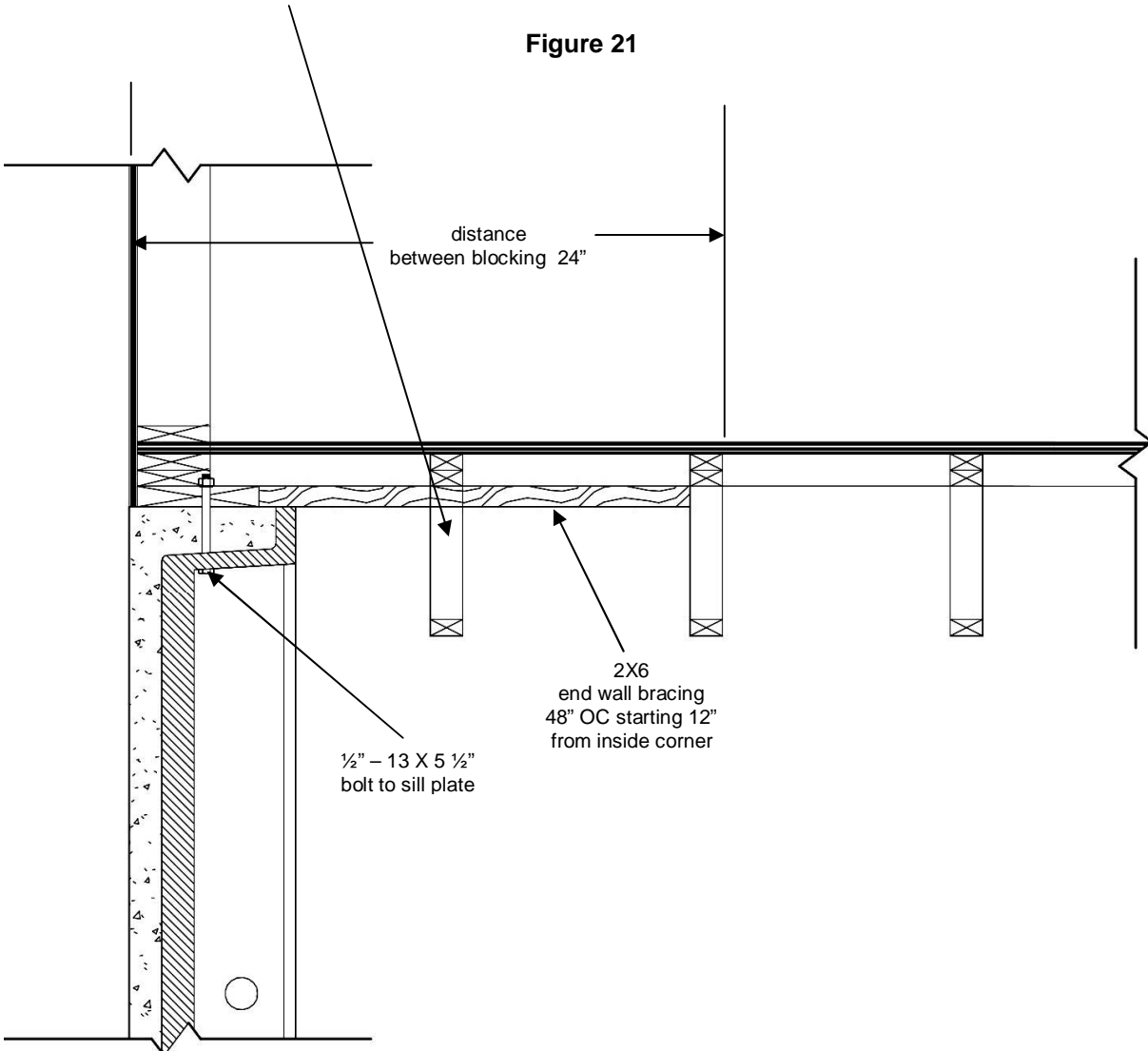

Bottom Chord Bearing Floor Truss

Parallel to MonoKast Panel

Figure 22

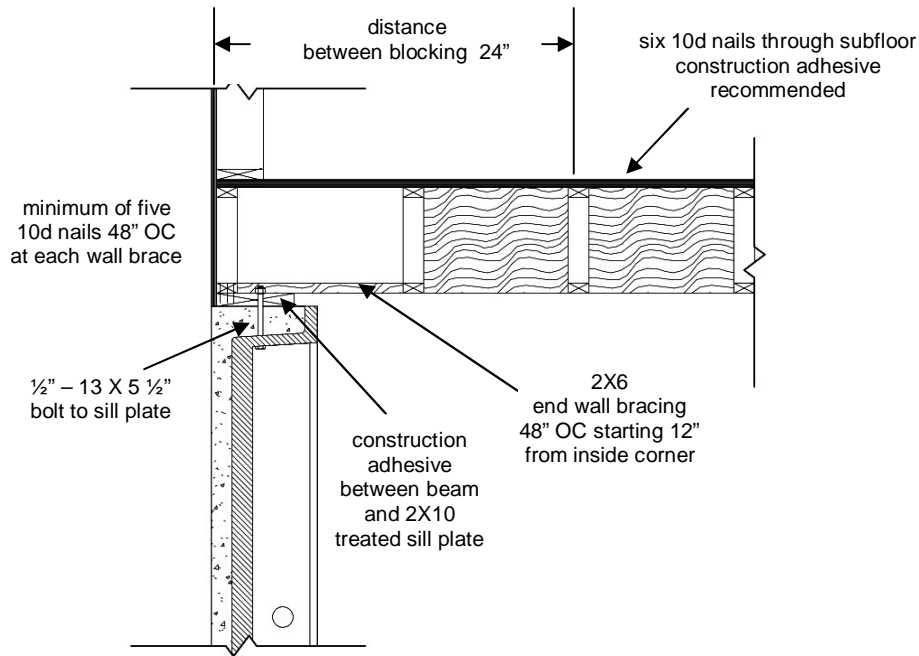

Perpendicular to MonoKast Panel

Figure 23

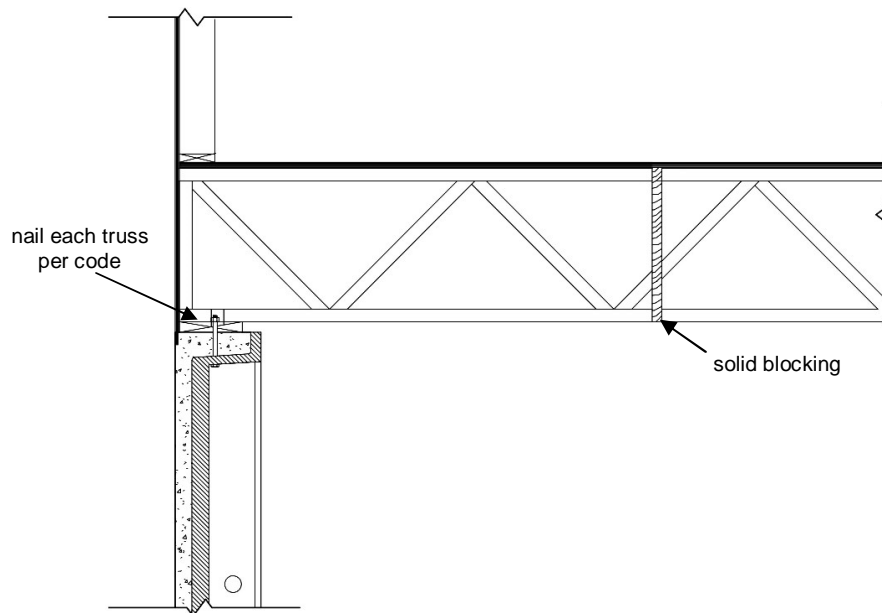

Sill Plate/Blocking for Modular Connection

1. The sill plate can be attached to the top of the MonoKast panel prior to the modular placement if it is not attached during the modular construction.
2. If the sill plate and required blocking are completed during modular construction, the blocking/bracing should be installed per Figure 16 on page 25.
3. Use construction adhesive between the bond beam and the sill plate.
4. Use two washers (one above the wood sill plate and one between the nut and the underside of the bond beam) to bolt the sill plate with minimum $\frac{1}{2}$ " x $5\frac{1}{2}$ " bolts through the precast holes in the top bond beam.
5. Nail each joist to the sill plate with, minimum, two 16d nails. If it is difficult to nail the joists to the sill plate, use the MonoKast framing straps.
6. Use the 1-1/2" galvanized nails to fasten the framing strap between the band joist and the sill plate.
7. Use one nail in each hole of the framing strap. The framing strap should be nailed to the sill plate before setting the structure.
8. **Use five 10d nails every 48" on center** to nail a 2 x 6 end wall brace securely to the sill plate.
9. The end wall brace must be within 12" from each corner interior.
10. If a shear wall is required, see page 37 for instructions.

Figure 24

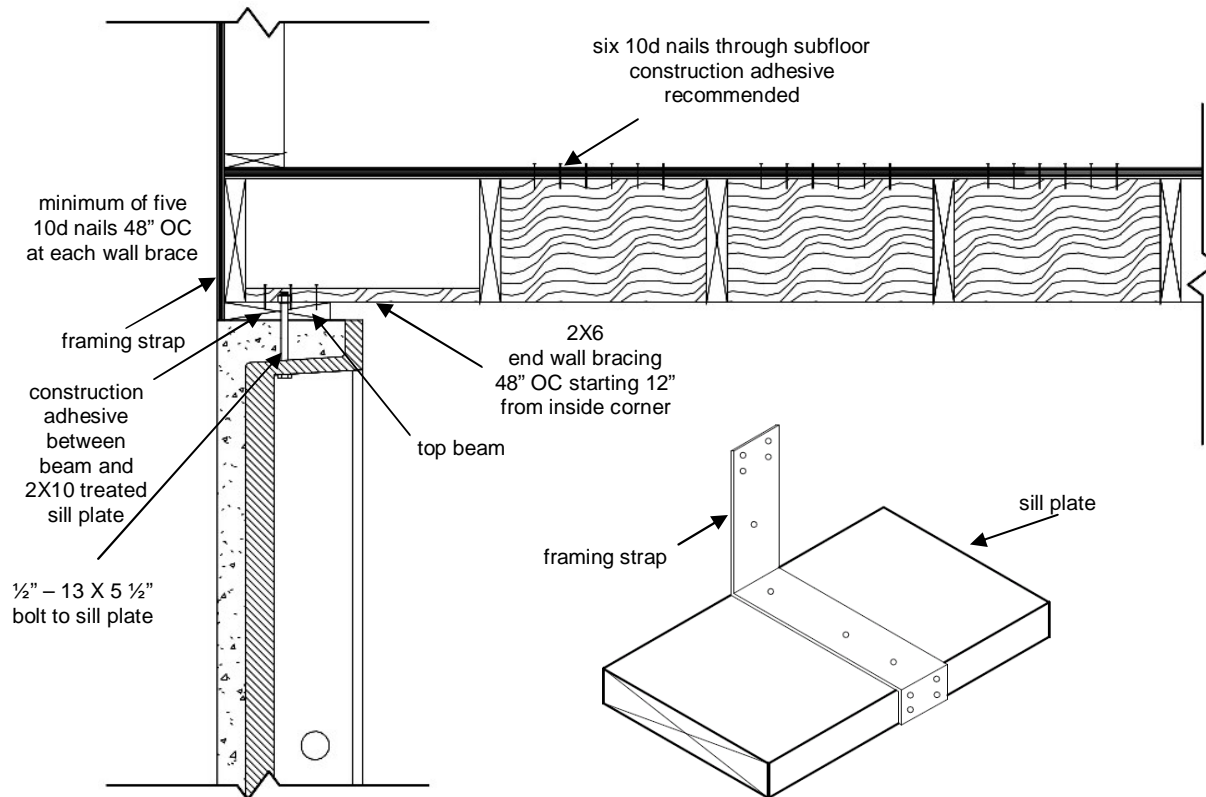

Connecting the Roof Truss

Note: Roof trusses may require structural cross bracing and/or uplift clips, depending on such factors as plan dimensions, site conditions or design details. Consult your design professional to determine whether you need structural cross bracing and/or uplift clips.

Code Reference: 2012 IRC Section: R802

SECTION R802 Wood Roof Framing. See code for requirements.

Figure 25

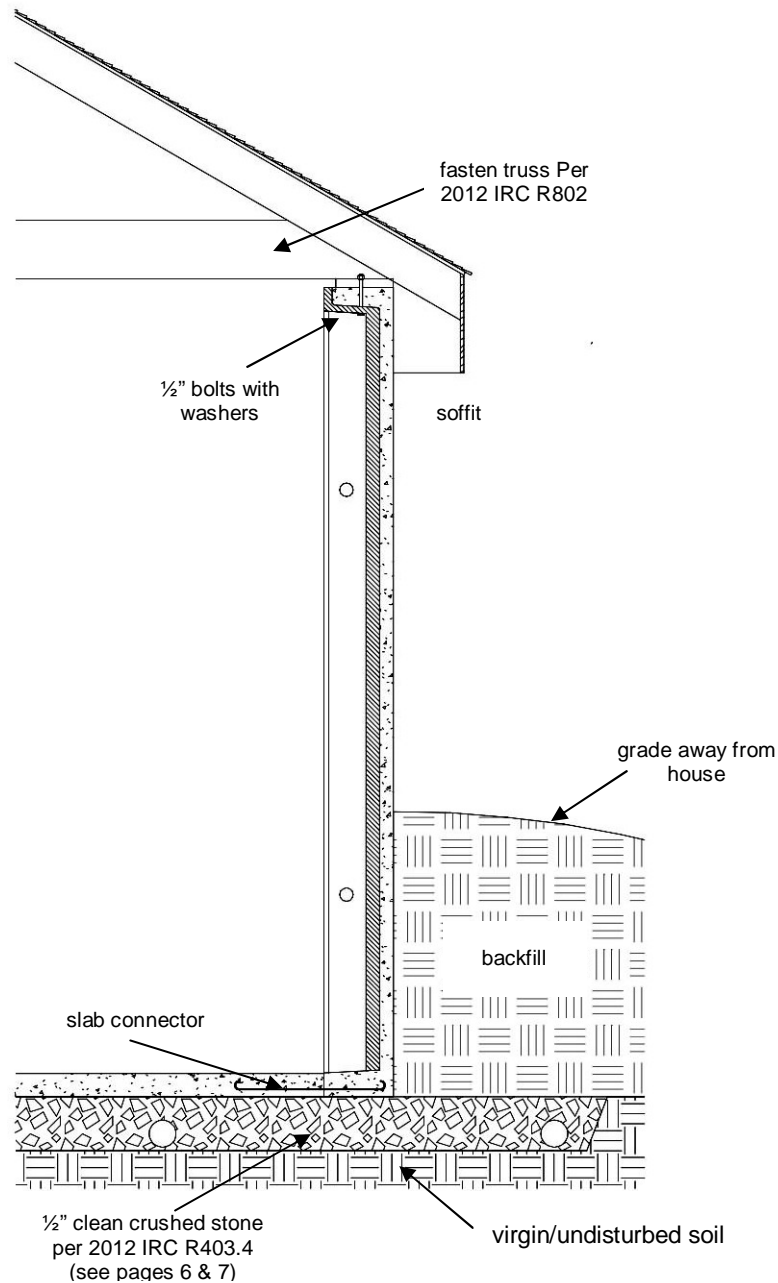

Stairwell Header Reinforcement

When stairwell openings are adjacent to the MonoKast wall, the wall often acts as a retaining wall with no top of wall restraint. If stairwell openings are up to 9'-6" in length and within 8' of the MonoKast panels:

1. Use construction adhesive between the sill plate and the top bond beam of the MonoKast panel.
2. Using a 2 x 10 sill plate and two 2 x 8s, build a support beam without splices.
3. The support beam should extend at least 24" beyond each end of the stairwell opening.
4. Use 1/2" bolts and washers to bolt the support beam. Use the bolts and washers at every bolt or insert location provided in the bond beam over the length of the support beam.
5. If the stairwell opening is more than 9'-6" in length, consult an engineer or your MonoKast representative.

Soil Type	8'	9'	10'
GW, GP, SW, SP	OK	OK	OK
GM, SM, GC, ML	OK	Backfill with clean crushed stone.	Backfill with clean crushed stone.
SC, CL	Backfill with clean crushed stone.	Backfill with clean crushed stone.	Backfill with clean crushed stone.

* Maximum height of backfill is 6" below the top of the wall.

Parallel Joists

Figure 26

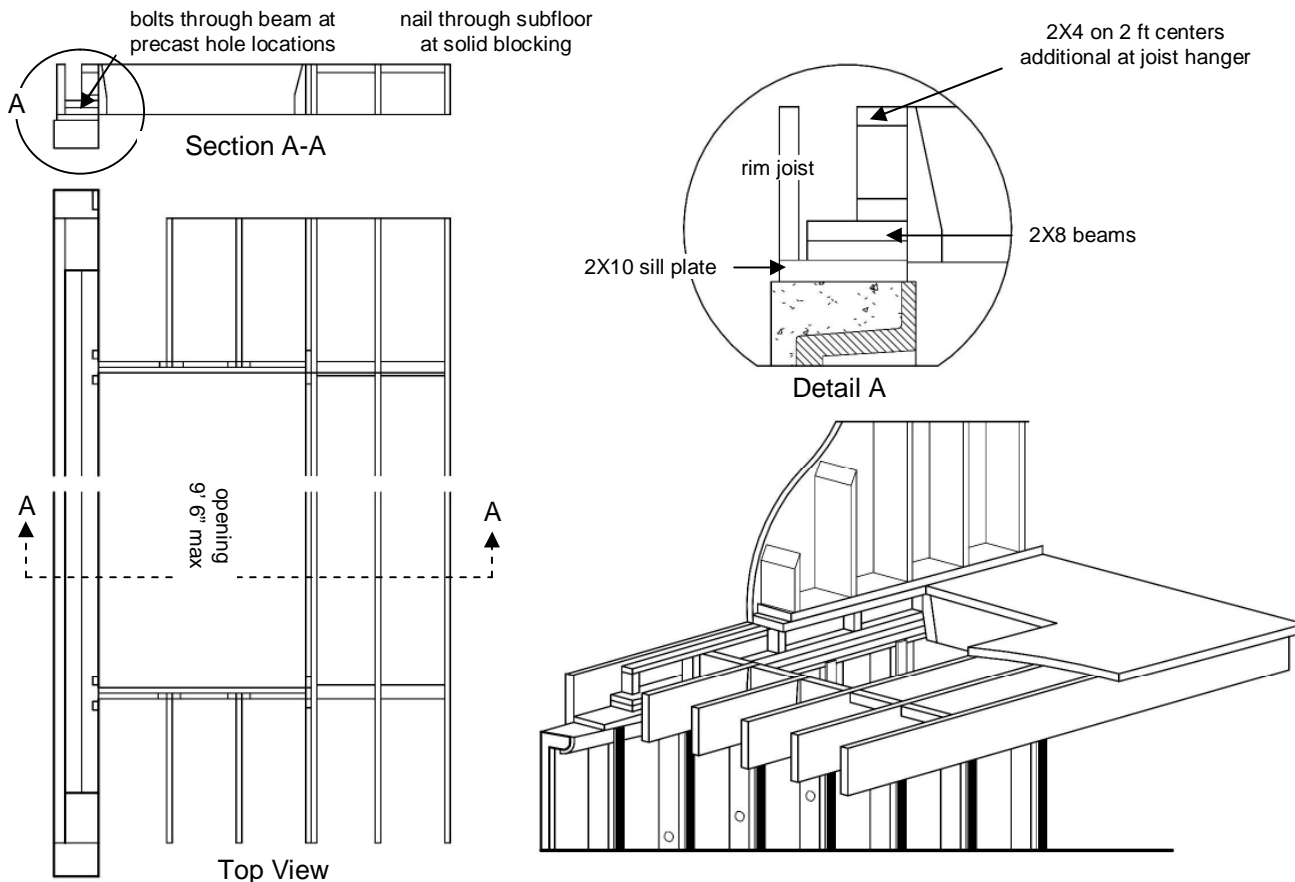

Perpendicular Joists

Figure 27

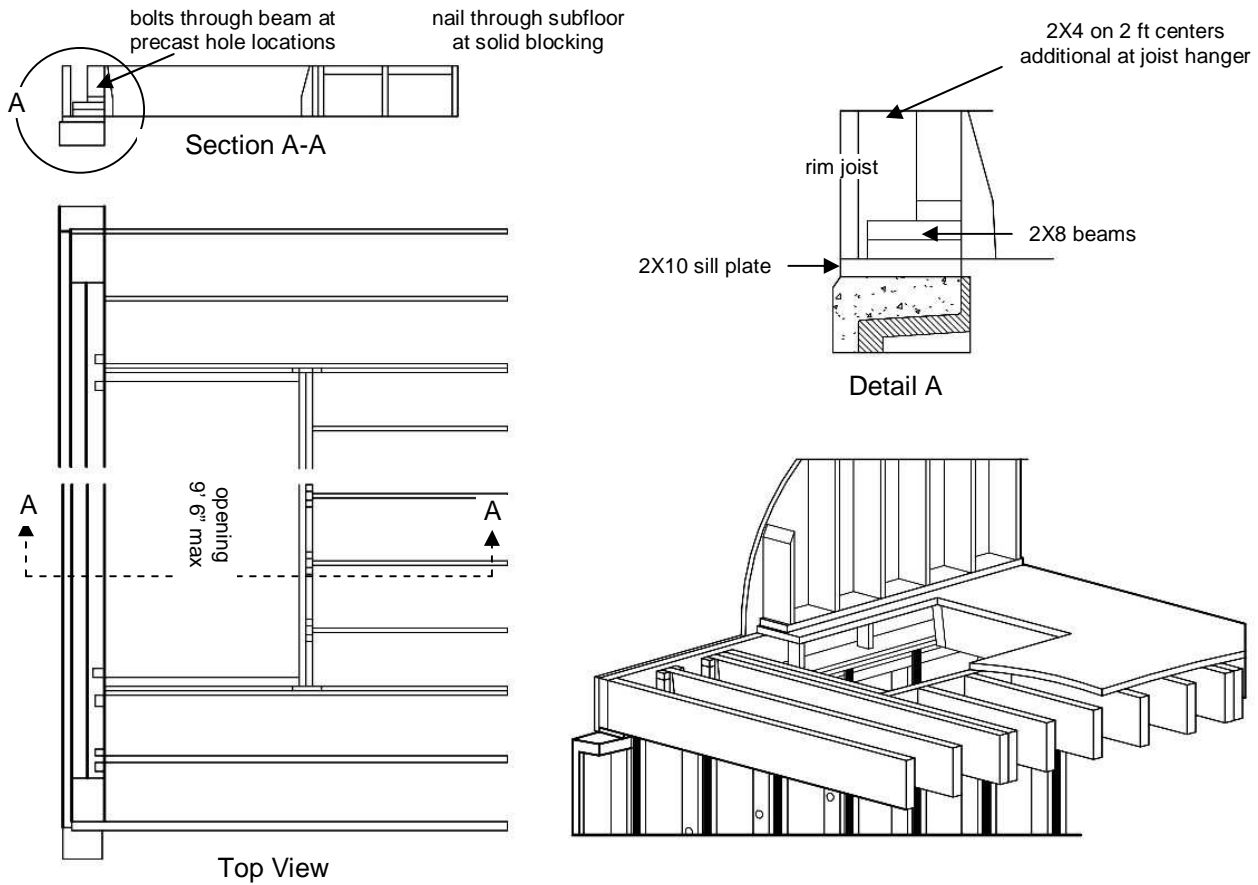

About Backfilling

1. Per 2012 IRC Section: R404.1.7 requirements, the framing / decking connection at the top of the MonoKast panel and the floor slab at the bottom of the MonoKast panel must be completed prior to backfilling.
2. The builder must ensure proper site conditions.
3. Expansive soil or topsoil should not be used for backfill. To determine soil type, refer to Table 1 on page 6.
4. Any backfill application must be less than 60 pounds per cubic foot equivalent fluid pressure. If the backfill exceeds 60 pounds per cubic foot equivalent fluid pressure, consult a design professional.
5. The backfill must be less than 6" below the top of the MonoKast panel.
6. Slope the ground away from the MonoKast walls according to local code, but not less than a 6" fall within the first 10 feet. Establish rain gutters, downspouts, and run-outs. Do not run downspouts to the foundation drain.
7. Avoid operating heavy equipment near backfilled walls.
8. If there is more backfill inside than outside, the maximum differential is 36". For projects that require backfill differential more than 36", discuss additional requirements with your MonoKast representative prior to panel manufacturing.
9. For Overdig of more than 36" MonoKast recommends use of stone backfill for the lower 24"
10. For walls with over 9 ft of backfill MonoKast recommends stone backfill for the first 2/3 of backfill and then clean soil

Code Reference: 2012 IRC Section: R401.3

R401.3 Drainage. Surface drainage shall be diverted to a storm sewer conveyance or other *approved* point of collection that does not create a hazard. *Lots* shall be graded to drain surface water away from foundation walls. The *grade* shall fall a minimum of 6 inches (152 mm) within the first 10 feet (3048 mm).

Exception: Where *lot lines*, walls, slopes or other physical barriers prohibit 6 inches (152 mm) of fall within 10 feet (3048 mm), drains or swales shall be constructed to ensure drainage away from the structure. Impervious surfaces within 10 feet (3048 mm) of the building foundation shall be sloped a minimum of 2 percent away from the building.

Code Reference: 2012 IRC Section: R404.1.6

R404.1.6 Height above finished grade.

Concrete and masonry foundation walls shall extend above the finished *grade* adjacent to the foundation at all points a minimum of 4 inches (102 mm) where masonry veneer is used and a minimum of 6 inches (152 mm) elsewhere.

Code Reference: 2012 IRC Section: R404.1.7

R404.1.7 Backfill placement. Backfill shall not be placed against the wall until the wall has sufficient strength and has been anchored to the floor above, or has been sufficiently braced to prevent damage by backfill.

NO Exception: MonoKast does not permit the utilization of any exception.

Determining the Need for a Shear Wall

In certain uneven backfill or open floor plan conditions, a shear wall may be needed to provide lateral stability. If a shear wall is required, the architect or engineer should specify location, length, bottom of wall connections and top of wall connection in the architectural drawings. The shear wall can be constructed from wood, concrete, masonry (CMU) or steel.

The following table can be used to determine if a shear wall is required.

Table 5: Maximum Wall Length Without a Shear Wall				
Wall Height	Differential Backfill Height	Soil Type		
		SC, CL	GM, SM, GC, ML	GW, GP, SW, SP
8'-2"	≤7'-6"	27'-0"	36'-0"	54'-0"
	≤7'-0"	32'-0"	44'-0"	66'-0"
	≤6'-0"	52'-0"	70'-0"	105'-0"
9'-0"	≤8'-4"	21'-6"	29'-0"	42'-0"
	≤7'-0"	36'-0"	48'-0"	72'-0"
	≤6'-0"	58'-0"	76'-0"	116'-0"
10'-0"	≤9'-4"	18'-0"	23'-0"	34'-0"
	≤8'-0"	27'-0"	36'-0"	54'-0"
	≤7'-0"	40'-0"	54'-0"	80'-0"
	≤6'-0"	64'-0"	86'-0"	128'-0"

Figure 29

per 2012 IRC Section R404.1.7 requirements, the framing / decking connection at the top of the MonoKast panel and the floor slab at the bottom of the MonoKast panel must be completed prior to backfilling

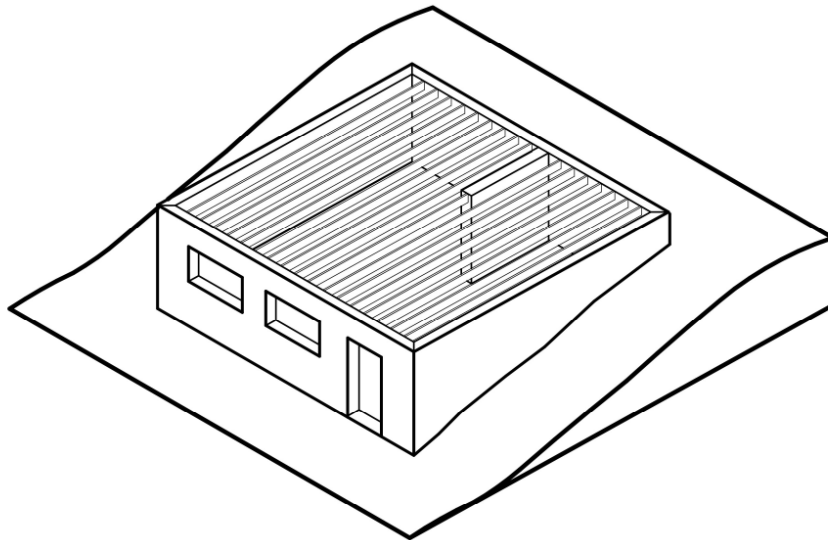

Concentrated Loads

Concentrated loads must be identified to ensure that the factory provides the proper structural members to support it. Concentrated loads that must be considered are:

- A load that will rest directly on the sill plate or bond beam
- A load that exceeds the project's uniformly distributed load on the wall
- Any isolated load (e.g. a column load)

Beam Pockets

Identify beam pockets needed to support beams located below floor joist.

When ordering beam posts, specify:

- Location
- Width
- Height
- Design Loading

Code Reference: 2012 IRC Section: R606.14

R606.14 Beam supports. Beams, girders or other concentrated loads supported by a wall or column shall have a bearing of at least 3 inches (76 mm) in length measured parallel to the beam upon *solid masonry* not less than 4 inches (102 mm) in thickness, or upon a metal bearing plate of adequate design and dimensions to distribute the load safely, or upon a continuous reinforced masonry member projecting not less than 4 inches (102 mm) from the face of the wall.

Figure 30



Support Ledges

1. Ledges can support brick or stone veneers; adjoining walls; and garage, porch or patio floor pours.
2. The ledges can be either 4" or 6" (both are rated for 2,900 pounds) and can be either continuous or intermittent. You must specify the vertical and horizontal location.
3. Consult the building code reference for flashing requirements.

Code Reference: 2012 IRC Section: R703.7

R703.7 Stone and masonry veneer, general. See code for requirements.

Figure 31

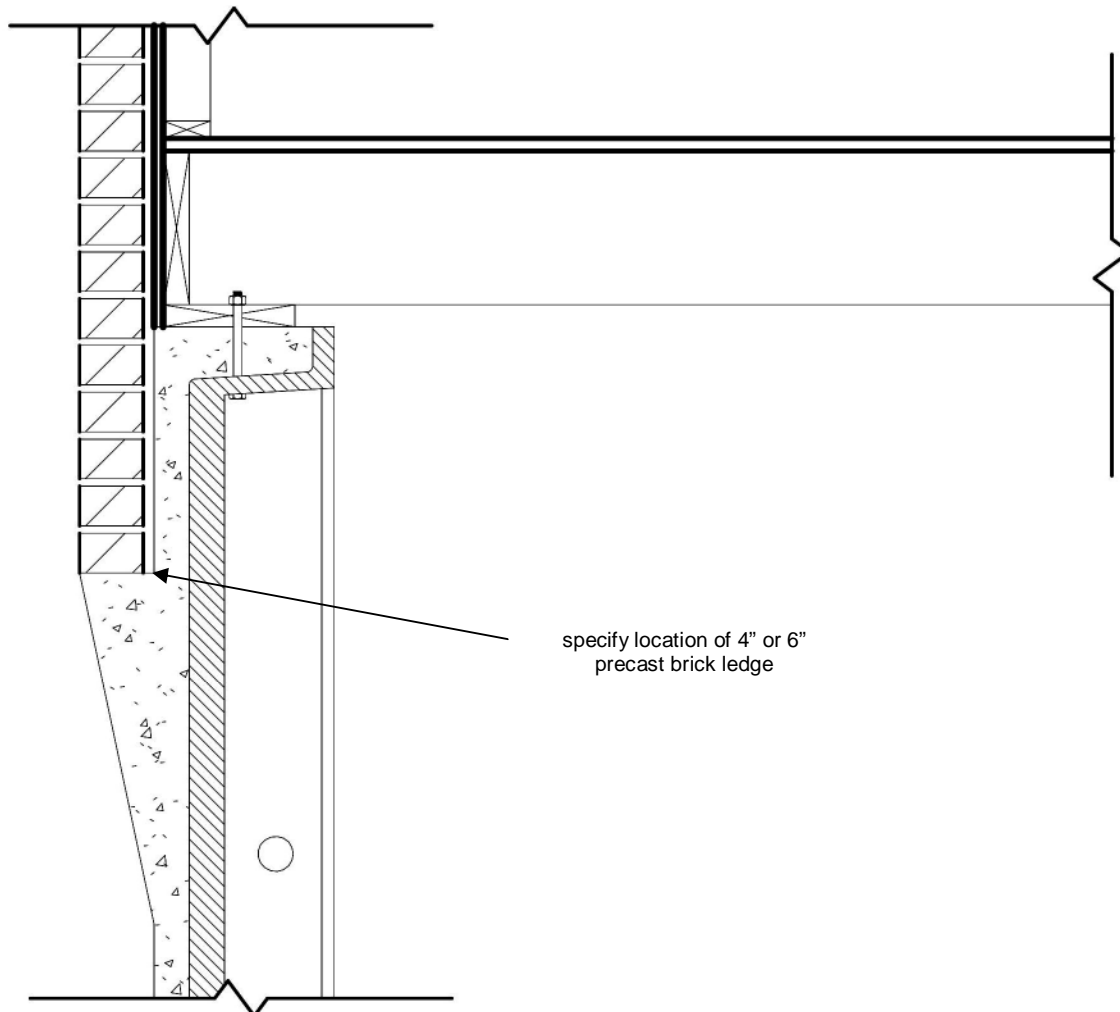

MonoKast Checklist for Builder/General Contractor

Your MonoKast representative has been given:

- Floor plan
- Elevation at the top of the foundation
- Design load per linear foot on the foundation
- Location of beam and column
- Size of beam and column
- Point load of beam and column
- Location of windows
- Opening size of windows
- Location of doors
- Opening size of doors
- Location of interior stairways
- Opening size of interior stairways
- Egress considerations
- Exterior finishes that require support ledges
- Inside fill conditions
- System specifications of exterior basement entry

Site Preparation:

- Building permits
- Building inspections
- Excavation
- Drainpipe placement
- Sump pit placement
- Filter membrane has been installed
- Cold weather practice
- Crushed stone footing placement
- Corner markers are placed
- Grade is established
- Site is accessible for truck and crane
- Site has a trailer unload area
- Site has a crane pad
- Sill plate has been installed
- Framing attachments have been installed
- Framing/Decking connection is complete

The checklist from the MonoKast Builders Manual has been provided for:

- Excavation
- Concrete floor
- Framing
- Inspection

Crushed Stone Footing:

- Stone depth has been determined (Table 2 of MonoKast Builders Manual – see page 7)
- Stone depth has been communicated to excavator

Drainage System and Daylight Drain or Sump:

- Placement of perforated drainpipe in reference to corner marker location has been communicated to excavator
- Location of daylight drain and trap has been communicated to excavator
- Location of sump accumulation tank (if applicable) has been communicated to excavator

Shear Walls:

- Need for shear walls has been verified
- Shear walls are attached to floor, outside wall and joist(s) above, if required
- Shear wall construction has been communicated to framers

Crawl Space:

- One of the following has been chosen:
 - Treated 2X6 end wall bracing & blocking 48" OC & within 12" of each corner
 - 12" minimum inside fill
 - 2" minimum poured concrete fill

Framing/Modular Connection:

Note: Building code requires that the framing/decking connection at the top of the MonoKast panel and the floor slab at the bottom of the MonoKast panel be completed **prior** to backfilling.

- Fastening schedule has been determined
- Fastening schedule has been communicated to framers
- The sill plate is bolted within 12" of the end of all plate sections, per 2012 IRC – R403.1.6 (page 22)
- If a framing strap is used, it lies between the sill plate and the band joist
- If a framing strap is used, it is fastened with 1-1/2" nails, one nail per hole
- If a framing strap is used, strap facing has been verified

Electrical/Plumbing:

- The proper method to drill holes through the MonoKast panels has been communicated

MonoKast Checklist for Excavator

MonoKast Builders Manual

- I have a copy of the MonoKast Builders Manual

Approved Drawings

- I am working from the approved excavation drawing

Soil Verification:

- Soil type has been determined (Table 1 of MonoKast Builders Manual – see page 6)
- Allowable load-bearing pressure has been determined
- Combined footing load per linear foot has been determined

Building Location:

- I have benchmark elevations from the builder
- The builder has placed corner markers

Excavation Topics:

- The trench has been dug below the frost line
- There is a minimum 2-foot overdig at the foundation base of both sides of the MonoKast wall
- Banks are properly benched
- If the excavation is more than 5 feet deep, the bench is per OSHA Standard 1926.652
- There is ramp access to the hole
- The soil is piled a safe distance from the hole
- There is driveway access for truck and crane
- Trailer location pads have been prepared
- Crane pads have been prepared
- MonoKast recommends a maximum 36" overdig outside MonoKast walls. If overdig exceeds 36" MonoKast recommends backfilling with 24" of stone then cover with clean soil

Crushed Footing:

- The footing has been dug per the required stone depth (Table 2 of MonoKast Builders Manual, page 7)
- Perforated pipe (if required by 2012 IRC R405.1 - see Table 1 of MonoKast Builders Manual, page 6) or the equivalent is used for water collection
- The drainpipe has been placed at least one foot (12") beyond the nearest MonoKast Wall
- The crushed stone has been cleaned
- The stone has been consolidated in a maximum of 8" lifts with the plate vibrator
- The drainpipe is directed toward accumulation tanks or daylight
- The stone is evenly graded within ½" of level
- There is enough stone left for final grading
- The filter membrane has been installed as required by local code

Backfill:

Note: Building code requires that the framing/decking connection at the top of the MonoKast panel and the floor slab at the bottom of the MonoKast panel be completed **prior** to backfilling.

- The builder has given approval for backfill
- Expansive soil or topsoil should not be used for backfill. To determine soil type, refer to Table 1 of MonoKast Builders Manual, page 6.

- The backfill must be less than 6" below the top of the MonoKast panel.
- Slope the ground away from the MonoKast walls according to local code, but not less than a 6" fall within the first 10 feet. Establish rain gutters, downspouts, and run-outs. Do not run downspouts to the foundation drain.
- Avoid operating heavy equipment near backfilled walls.
- If there is more backfill inside than outside, the maximum differential is 36". For projects that require backfill differential more than 36", discuss additional requirements with your MonoKast representative prior to panel manufacturing.
- For Overdig of more than 36" MonoKast recommends use of stone backfill for the lower 24"
- For walls with over 9 ft of backfill MonoKast recommends stone backfill for the first 2/3 of backfill and then clean soil
- Any backfill application must be less than 60 pounds per cubic foot equivalent fluid pressure. If the backfill exceeds 60 pounds per cubic foot equivalent fluid pressure, consult a design professional.

MonoKast Checklist for Concrete Floor Work

MonoKast Builders Manual

- I have a copy of the MonoKast Builders Manual

Approved Drawings

- I am working from the approved concrete work drawing

Crawl Space:

- One of the following has been chosen:
 - Treated 2X6 end wall bracing & blocking 48" OC & within 12" of each corner
 - 12" minimum inside fill
 - 2" minimum poured concrete fill

Concrete Floor:

Note: Building code requires that the framing/decking connection at the top of the MonoKast panel and the floor slab at the bottom of the MonoKast panel be completed **prior** to backfilling

- There is a clean 4" base of ½" clean crushed stone per 2012 IRC R403.4 (see page 7)
- The thickness of the floor is at least 3-1/2"
- Slab connectors were bent down before pouring floor – if provided
- There is at least 2 inches of concrete contact between the base of the wall and the floor

Raised Concrete Floor:

- There is a clean 4" base of ½" clean crushed stone per 2012 IRC R403.4 (see page 7)
- The thickness of the floor is at least 3-1/2"
- Raised concrete floors are created using one of two options illustrated in Figure 9 on page 16 of the MonoKast Builders Manual

MonoKast Checklist for Framing

MonoKast Builders Manual

- I have a copy of the MonoKast Builders Manual

Approved Drawings

- I am working from the approved framing drawing

Crawl Space:

- One of the following has been chosen:
 - Treated 2X6 end wall bracing & blocking 48" OC & within 12" of each corner
 - 12" minimum inside fill
 - 2" minimum poured concrete fill

Sill Plate:

- The builder has supplied the sill plate bolting frequency – MonoKast recommends 24" OC
- The bolts in the top bond beam are a minimum of ½" x 5-1/2"
- The sill plate is fastened above the window and door headers using coil bolts or equivalent
- There are at least two bolts per sill plate section
- The sill plate is within one foot of the end of all plate sections, per 2012 IRC-R403.1.6 (page 22)
- The sill plate splices are at least 4 feet from any MonoKast panel joint
- MonoKast recommends construction adhesive between beam and 2X10 treated sill plate

Perpendicular Floor Joist:

- Each joist is nailed to the sill plate with, minimum, two 16d nails

Parallel Floor Joist:

- There is a 2 x 6 end wall brace every 4 feet
- There is a 2 x 6 end wall brace within 1 foot of each interior corner
- The 2 x 6 end wall brace is nailed to the sill plate with **five 10d nails**
- The builder has supplied the required number of solid blocks
 - o If backfill is less than 7'-6", nail 1 solid block in line with the 2 x 6 end wall brace
 - o If backfill is between 7'-6" and 9'-6" for joists less than 10', use 2 solid blocks.
 - o Use 3 solid blocks for joists 10' or more, when backfill is between 7'-6" and 9'-6"
- If conventional construction, there are a minimum of six 10d nails through subfloor (construction adhesive recommended)
- If modular construction, there is construction adhesive on the top of blocking

Modular:

- The builder has supplied the required spacing for framing straps
- The framing straps are between the band joist and sill plate
- The framing strap is nailed with the 1 ½" nails provided with the straps
- There is 1 nail in every nail hole

Shear Wall:

- If the builder has determined that a wooden shear wall is required

- The shear wall is attached to the concrete floor, wall and floor joist per MonoKast design specifications

Stairwell Header:

- The long side of the stairway opening is within 8 feet of the parallel MonoKast panel
- There is a support beam (2 x 10 sill plate and two 2 x 8s)
- The support beam is 2 feet past each end of the stairwell opening
- If the long side of the stairway opening is larger than 9'-6", an engineer has reviewed the opening

Roof Truss:

- The builder has supplied the sill plate bolting frequency
- The builder has verified what structural cross bracing is required for the trusses
- The builder has verified whether uplift clips are required for the trusses

MonoKast Checklist for Code Inspector

Soil:

- The soil is minimum 1,500 PSF capacity

Crushed Stone Footing:

- The crushed stone is the correct depth (Table 2 of MonoKast Builders Manual, pages 7)
- The crushed stone is clean from any organic, clayey or silty soils
- The filter membrane was installed prior to backfill

Excavation:

- The trench is dug below the frost line

Drainage System/Sump Pump:

- A drainage pipe has been installed
- There is an accumulation tank for the sump if there is not draining to daylight

Concrete Floor:

- The floor thickness is at least 3-1/2"
- There is a vapor retarder under the floor
- There is at contact between the base of the wall and the concrete floor
- Slab connectors (if used) were bent into the concrete floor pour

Crawl Space:

- One of the following is present:
 - Treated 2X6 end wall bracing & blocking 48" OC & within 12" of each corner
 - 12" minimum inside fill
 - 2" minimum poured concrete fill

Sill Plate:

- The bolts in the top bond beam are a minimum of 1/2" x 5-1/2"
- The sill plate is fastened above the window and door headers with coil bolts or equivalent
- There are at least two bolts per sill plate section
- The sill plate is within one foot of the end of all plate sections, per 2012 IRC-R403.1.6 (page 22)
- The sill plate splices are at least 4 feet from any MonoKast panel joint

Perpendicular Floor Joist:

- Each joist is nailed to the sill plate with, minimum, two 16d nails

Parallel Floor Joist:

- There is a 2 x 6 end wall brace every 4 feet
- There is a 2 x 6 end wall brace within 1 foot of each interior corner
- The 2 x 6 end wall brace is nailed to the sill plate with a minimum of **five 10d nails** 48" OC
- There is the required number of solid blocks
- If conventional construction, there are six 10d nails through the floor
- If modular construction, there is construction adhesive on the top of blocking

Modular Connection:

- There is the required spacing for framing straps
- The framing straps are between the band joist and sill plate
- The framing strap is nailed with the 1 ½" nails provided with the straps
- There is 1 nail in every nail hole

Shear Wall:

- The builder has determined if a wooden shear wall is required
- If required, the shear wall is attached to the concrete floor, wall and floor joist per MonoKast design specifications

Stairwell Header:

- The long side of the stairway opening is within 8 feet of the parallel MonoKast panel
- There is a support beam (2 x 10 sill plate and two 2 x 8s)
- The support beam is 2 feet past each end of the stairwell opening
- If the long side of the stairway opening is larger than 9'-6", an engineer has reviewed the opening

Backfill:

- The basement floor was poured before backfilling
- The first floor framing/decking was properly attached before backfilling, per IRC-R404.1.7)

Inside Fill:

- The inside fill is no more than 3 feet more than the outside fill

Final Grade:

- There is a minimum of 6" fall within the first 10 feet of the solid grade
- The height above the finished soil grade is at least 6"